

# Texaking

OPEN MULTI DECK  
REACH-IN GLASS DOOR  
SERVICE CASES

Daniel Kwon (Sales Manager)

Tel. 214-723-7205

Cell. 310-483-0643

daniel@turboairinc.com

***BEST QUALITY & PRICE  
GREAT CUSTOMER SERVICE***

***QUICK DELIVERY FROM 13 LOCATIONS***



1800 S. Great SW Pkwy.,  
Grand Prairie, TX 75051



[www.texaking.com](http://www.texaking.com)



1-800-828-2706

# Global Turbo Air Group

Manufacturing Divisions



**Selling to 67 Countries**

[www.turboairinc.com](http://www.turboairinc.com)

# BRANCH / DISTRIBUTION LOCATION

## CALIFORNIA

### Headquarters

4184 E. Conant St., Long Beach, CA 90808  
Tel: 310-900-1080 / Fax: 310-900-1088  
Toll Free: 888-900-1002 / Warranty Service: 888-900-1002  
[www.turboairinc.net](http://www.turboairinc.net)



### OAKLAND



1617 Whipple Rd., Suite A, Hayward, CA 94544  
Tel: 888-900-1002 Fax: 310-900-1088

### HAWAII



179 Sand Island Access Rd., #B, Honolulu, HI 96819  
Tel: 888-900-1002 Fax: 310-900-1088

### SEATTLE



2515 142nd Ave E. Sumner, WA 98390  
Tel: 888-900-1002 Fax: 310-900-1088

### DENVER



3650 Fraser St., Unit C, Aurora, CO 80011  
Tel: 888-900-1002 Fax: 310-900-1088

### CHICAGO



101 E. Crossroads Pkwy., Suite B, Bolingbrook, IL 60440  
Tel: 888-900-1002 Fax: 310-900-1088

### CINCINNATI



12080 Best Place, Sharonville, OH 45241  
Tel: 888-900-1002 Fax: 310-900-1088

### ATLANTA



5345 Buford Highway, Norcross, GA 30071  
Tel: 888-900-1002 Fax: 310-900-1088

### DALLAS



1800 S. Great Southwest Pkwy., Grand Prairie, TX 75051  
Tel: 888-900-1002 Fax: 310-900-1088

### HOUSTON



4300 N. Sam Houston Pkwy., W. #410, Houston, TX 77086  
Tel: 888-900-1002 Fax: 310-900-1088

### NEW JERSEY



10 Basin Dr., Suite 110, S.Kearny, NJ 07032  
Tel: 888-900-1002 Fax: 310-900-1088

### PITTSBURGH



201 Locust St., Youngwood, PA 15697  
Tel: 888-900-1002 Fax: 310-900-1088

### MIAMI



2701 SW 145th Ave., Suite 220, Miramar, FL 33027  
Tel: 888-900-1002 Fax: 310-900-1088

# OPEN MULTI DECK MERCHANDISERS



## ≡ FEATURES & BENEFITS ≡

- **LED lighting system standard (canopy only)**
- **LED light for shelves and third row (optional)**
- **ECM energy-efficient fan motors standard**
- **Off cycle defrost for cost-effective operation standard**
- **Bottom-mounted copper coil and lift-up fan duct with easily removable fan bracket and motor assembly for ease of maintenance**
- **Night curtains can be added to save energy costs**
- **TEXAKING display cases for sale in the United States meet or exceed DOE 2017 energy efficiency standards**
- **Ultra-low front for easy access to larger or heavier products (ED5-U model)**
- **Stainless steel seamless bottom liner provides corrosion resistant and enhanced sanitation**

# DAIRY / DELI OPEN CASES

## FRONT HEIGHT - STANDARD / HIGH / ULTRA LOW

### ELECTRICAL DATA (ED5, ED5-H)

Fans	4'	6'	8'	12'
Fans Per Case	2	3	3	4
Volts	120	120	120	120
Amps	0.3	0.45	0.45	0.6
Watts	36	54	54	72

### ELECTRICAL DATA (ED5-U)

Fans	4'	6'	8'	12'
Fans Per Case	2	3	4	6
Volts	120	120	120	120
Amps	0.3	0.45	0.6	0.9
Watts	36	54	72	108

### LIGHTING DATA

LED Lighting	4'	6'	8'	12'	
Light Length	4'	3'	4'	4'	
Canopy (2 Rows)	Amps	0.33	0.5	0.66	0.99
	Watts	40	66	80	120
Shelf (1 Row)	Amps	0.08	0.12	0.16	0.24
	Watts	10	16	20	30

### STANDARD OPTIONS

- Available length : 4', 6', 8', 12'
- Available shelf sizes: 16", 18", 20", 22"
- Full-view and square ends available w/ various interior finishes

### REFRIGERATION DATA

Evaporator (°F)	26	
Discharge Air (°F)	32	
Superheat Set Point at Bulb (°F)	6-8	
BTUH/ ft	Parallel	Conventional
	ED5, ED5-H	1350
ED5-U	1700	1800

### DEFROST DATA

Type	Timed-Off
Frequency (Hr)	4
Failsafe (Minutes)	45
Defrost Thermostat	Close on rise: Close 43°F, Open 33°F

### PHYSICAL DATA

Case	L (cabinet only)	T (include end panel)*	A
4' case	48-1/16 (1221mm)	51-5/16 (1301mm)	24 (610mm)
6' case	72-1/8 (1831.5mm)	75-3/8 (1911.5mm)	45-9/16 (1157mm)
8' case	96-1/8 (2442mm)	99-3/8 (2522mm)	55-15/16 (1421mm)
12' case	144-3/16 (3663mm)	147-7/16 (3743mm)	80 (2031.5mm)

\* Adding left & right end panels increases the overall cabinet length on the open multi deck merchandisers by 3-2/8"

Drain Pipe (in)	Liquid Line (in)	Suction Line (in)
SCH 40PVC PIPE	3/8	7/8

These Merchandisers are designed for use in stores when temperature and humidity do not exceed 75°F and 55% RH Design and specifications subject to change without notice.

- WARRANTY :** 12 months part only warranty from installation or 15 months part only warranty from shipment date

## ED5 MODELS SPECIFICATIONS

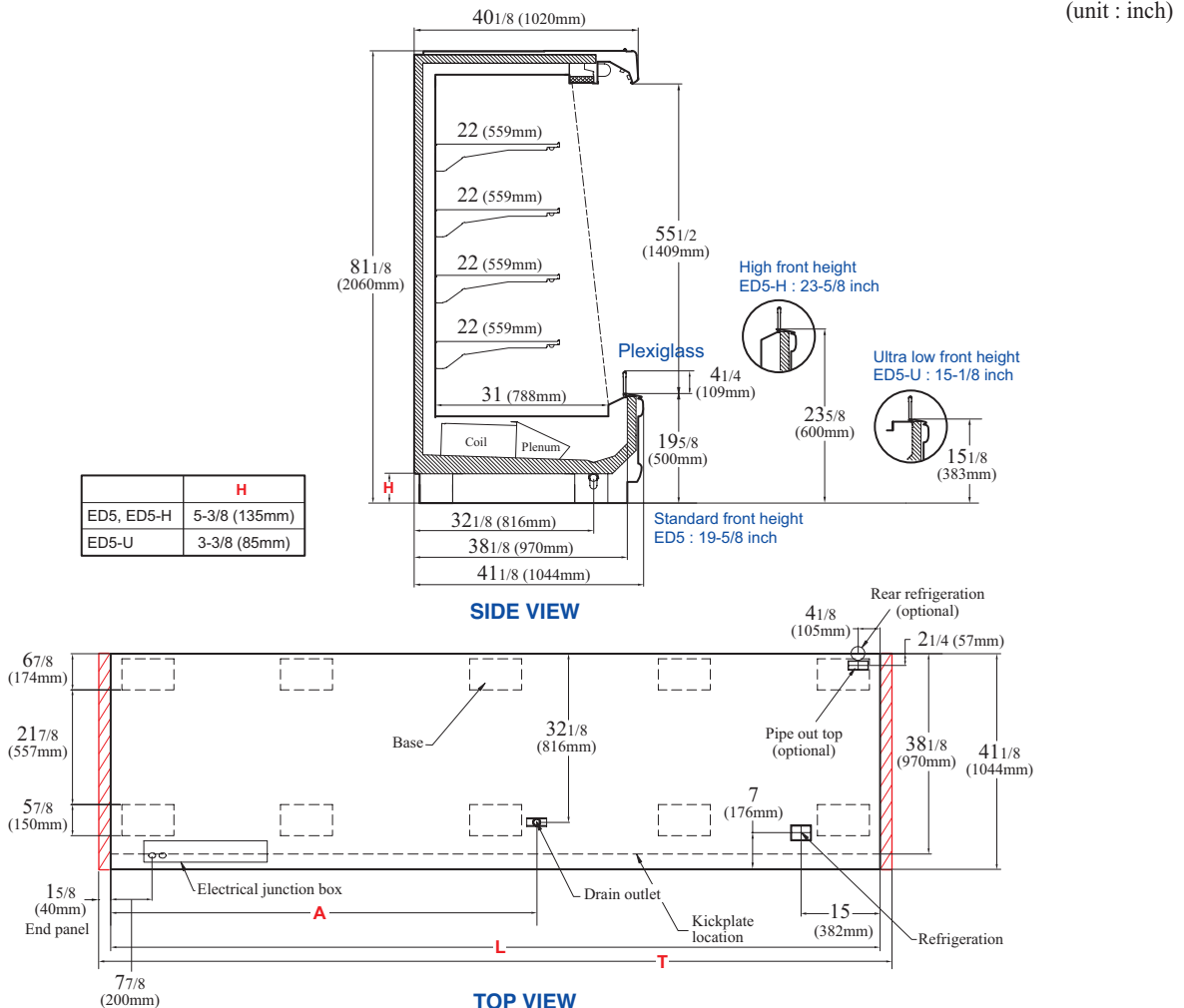



# MEAT OPEN CASES

## ELECTRICAL DATA

Fans	4'	6'	8'	12'
Fans Per Case	2	3	3	4
Volts	120	120	120	120
Amps	0.3	0.45	0.45	0.6
Watts	36	54	54	72

## LIGHTING DATA

LED Lighting	4'	6'	8'	12'	
Light Length	4'	3'	4'	4'	
Canopy (2 Rows)	Amps	0.33	0.5	0.66	0.99
	Watts	40	66	80	120
Shelf (1 Row)	Amps	0.08	0.12	0.16	0.24
	Watts	10	16	20	30

## STANDARD OPTIONS

- Available length : 4', 6', 8', 12'
- Available shelf sizes: 16", 18", 20", 22"
- Full-view and square ends available w/ various interior finishes
- Available mirror : 9", 13", 24"
- WARRANTY :** 12 months part only warranty from installation or 15 months part only warranty from shipment date

## REFRIGERATION DATA

Evaporator (°F)	23	
Discharge Air (°F)	29	
Superheat Set Point at Bulb (°F)	6-8	
BTUH/ft	Parallel	Conventional
	1190	1290

## DEFROST DATA

Type	Timed-Off
Frequency (Hr)	4
Failsafe (Minutes)	45
Defrost Thermostat	Close on rise: Close 43°F, Open 33°F

## PHYSICAL DATA

(unit : inch)

Case	L (cabinet only)	T (include end panel)*	A
4' case	48-1/16 (1221mm)	51-5/16 (1301mm)	24 (610mm)
6' case	72-1/8 (1831.5mm)	75-3/8 (1911.5mm)	45-9/16 (1157mm)
8' case	96-1/8 (2442mm)	99-3/8 (2522mm)	55-15/16 (1421mm)
12' case	144-3/16 (3663mm)	147-7/16 (3743mm)	80 (2031.5mm)

\* Adding left & right end panels increases the overall cabinet length on the open multi deck merchandisers by 3-2/8"

Drain Pipe (in)	Liquid Line (in)	Suction Line (in)
SCH 40PVC PIPE	3/8	7/8

These Merchandisers are designed for use in stores when temperature and humidity do not exceed 75°F and 55% RH. Design and specifications subject to change without notice.

## EM5 MODELS SPECIFICATIONS

(unit : inch)

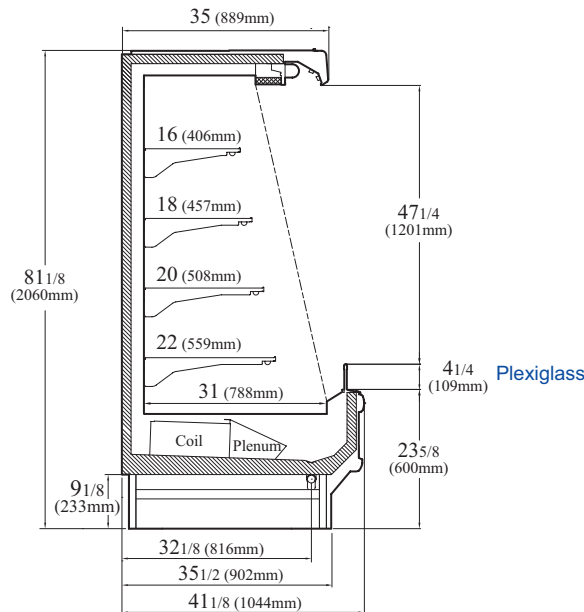

SIDE VIEW

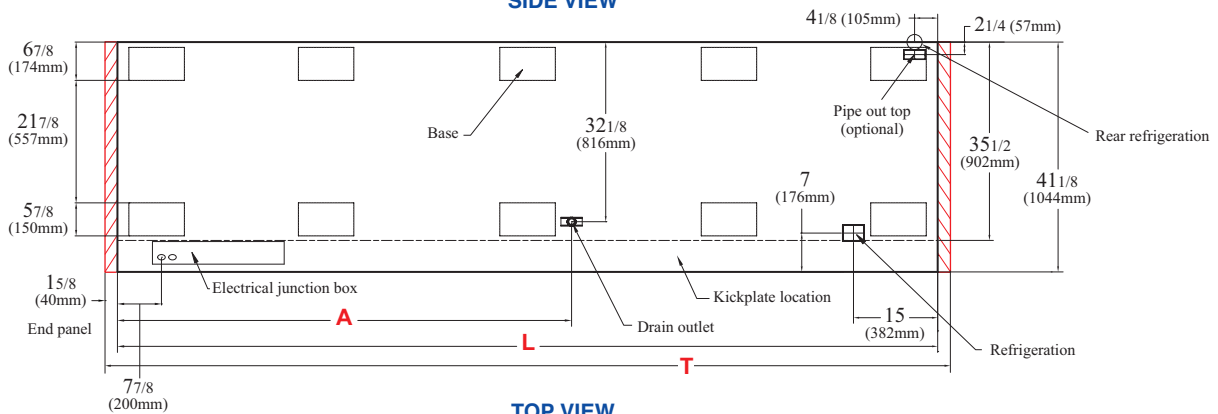

TOP VIEW

PLAN VIEW





# TOP FIELD MOUNTED CONDENSING UNIT OPEN MULTI DECK MERCHANDISERS



## ≡ FEATURES & BENEFITS ≡

- LED lighting system standard (canopy only)
- LED light for shelves and third row (optional)
- ECM energy-efficient fan motors standard
- Off cycle defrost for cost-effective operation standard
- Night curtains can be added to save energy costs
- Ultra-low front for easy access to larger or heavier products (ED5-U-C model)
- Stainless steel seamless bottom liner provides corrosion resistant and enhanced sanitation
- Bottom-mounted copper coil and lift-up fan duct with easily removable fan bracket and motor assembly for ease of maintenance
- Top field mounted condensing unit
- TEXAKING display cases for sale in the United States meet or exceed DOE 2017 energy efficiency standards
- Easy condensing unit installation: Refrigeration lines are pre-charged and pre-piped to top of case with quick-connect
- Pre-wired to simplify electrical connections
- No drains required: condensate removal system with field installed pump and condensation pan

# DAIRY / DELI OPEN CASES

FRONT HEIGHT - STANDARD / HIGH / ULTRA LOW

## ELECTRICAL DATA (ED5-C, ED5-H-C)

Fans	4'	6'	8'	12'
Fans Per Case	2	3	3	4
Volts	120	120	120	120
Amps	0.3	0.45	0.45	0.6
Watts	36	54	54	72

## LIGHTING DATA

LED Lighting	4'	6'	8'	12'	
Light Length	4'	3'	4'	4'	
Canopy (2 Rows)	Amps	0.33	0.5	0.66	0.99
	Watts	40	66	80	120
Shelf (1 Row)	Amps	0.08	0.12	0.16	0.24
	Watts	10	16	20	30

## CONDENSING UNIT

	4'	6'	8'	12'
Condensing Unit Model	FFAP-015Z-CFV-072	FFAP-022Z-CFV-071	FFAP-022Z-CFV-071	FFAP-032Z-CFV-071
Refrigerant Charge (R-404A, lbs)	4.0	6.0	8.0	10.0
Electrical Rating	115V/208V-1PH-60HZ : Red & Black Power, White Neutral, Green Ground			
MOCP (Amps) <sup>1)</sup>	25	40	45	60
MCA (Amps) <sup>2)</sup>	19.5	34.1	40.6	52.1

These Merchandisers are designed for use in stores when temperature and humidity do not exceed 75°F and 55% RH. Design and specifications subject to change without notice.

- 1) MOCP: Maximum over - current protection, Including condensing unit and condensate removal system.  
2) MCA: Minimum circuit ampacity, Including condensing unit and condensate removal system

## ELECTRICAL DATA (ED5-U-C)

Fans	4'	6'	8'	12'
Fans Per Case	2	3	4	6
Volts	120	120	120	120
Amps	0.3	0.45	0.6	0.9
Watts	36	54	72	108

## REFRIGERATION DATA

Evaporator (°F)	26		
Discharge Air (°F)	32		
Superheat Set Point at Bulb (°F)	6~8		
BTUH/ft		Parallel	Conventional
	ED5-C, ED5-H-C	1350	1450
	ED5-U-C	1700	1800

## DEFROST DATA

Type	Timed-Off
Frequency (Hr)	4

■ **WARRANTY :** 12 months part only warranty from installation or 15 months part only warranty from shipment date

## ED5-C MODELS SPECIFICATIONS

### PHYSICAL DATA

(unit : inch)

Case	L (cabinet only)	T (include end panel)*	A
4' case	48-1/16 (1221mm)	51-5/16 (1301mm)	24 (610mm)
6' case	72-1/8 (1831.5mm)	75-3/8 (1911.5mm)	45-9/16 (1157mm)
8' case	96-1/8 (2442mm)	99-3/8 (2522mm)	55-15/16 (1421mm)
12' case	144-3/16 (3663mm)	147-7/16 (3743mm)	80 (2031.5mm)

\* Adding left & right end panels increases the overall cabinet length on the open multi deck merchandisers by 3-2/8"

Drain Pipe (in)	Liquid Line (in)	Suction Line (in)
SCH 40PVC PIPE	3/8	7/8

	H
ED5-C, ED5-H-C	5-3/8" (135mm)
ED5-U-C	3-3/8" (85mm)

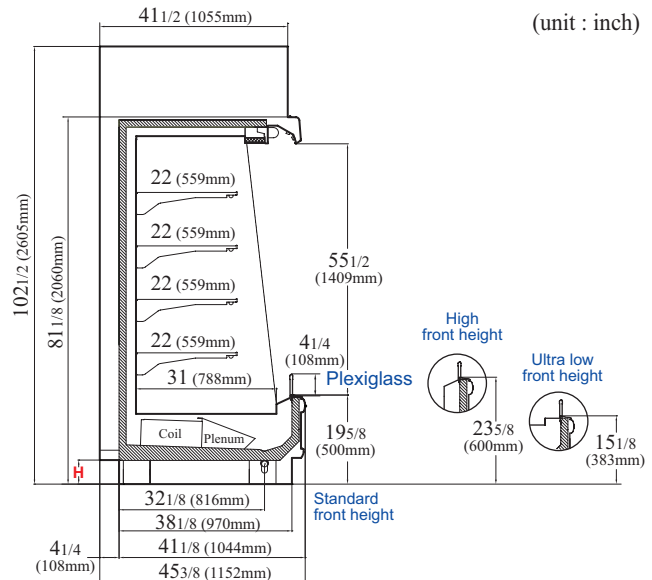

PLAN VIEW

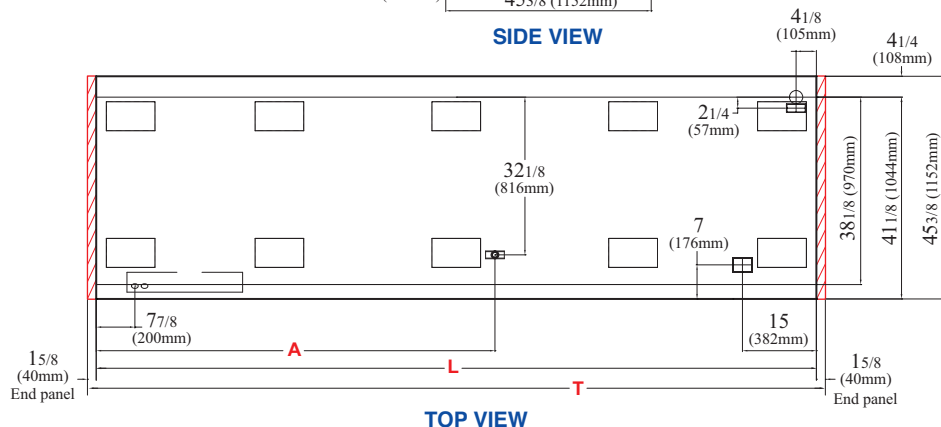

# DAIRY / DELI OPEN CASES - NARROW

## FRONT HEIGHT - STANDARD / HIGH

### ELECTRICAL DATA

Fans	4'	6'	8'	12'
Fans Per Case	2	3	3	4
Volts	120	120	120	120
Amps	0.3	0.45	0.45	0.6
Watts	36	54	54	72

### LIGHTING DATA

LED Lighting	4'	6'	8'	12'	
Light Length	4'	3'	4'	4'	
Canopy (2 Rows)	Amps	0.33	0.5	0.66	0.99
	Watts	40	66	80	120
Shelf (1 Row)	Amps	0.08	0.12	0.16	0.24
	Watts	10	16	20	30

### CONDENSING UNIT

	4'	6'	8'	12'
Condensing Unit Model	FFAP-015Z-CFV-072	FFAP-022Z-CFV-071	FFAP-022Z-CFV-071	FFAP-032Z-CFV-071
Refrigerant Charge (R-404A, lbs)	4.0	6.0	8.0	10.0
Electrical Rating	115V/208V-1PH-60HZ : Red & Black Power, White Neutral, Green Ground			
MOCP (Amps) <sup>1</sup>	25	40	45	60
MCA (Amps) <sup>2</sup>	19.5	34.1	40.6	52.1

These Merchandisers are designed for use in stores when temperature and humidity do not exceed 75°F and 55% RH. Design and specifications subject to change without notice.

1) MOCP: Maximum over - current protection, Including condensing unit and condensate removal system. 2) MCA: Minimum circuit ampacity, Including condensing unit and condensate removal system

### REFRIGERATION DATA

Evaporator (°F)	26	
Discharge Air (°F)	32	
Superheat Set Point at Bulb (°F)	6~8	
BTUH/ft	Parallel	Conventional
	1460	1560

### DEFROST DATA

Type	Timed-Off
Frequency (Hr)	4

### STANDARD OPTIONS

- Available length : 4', 6', 8', 12'
- Full-view and square ends available w/ various interior finishes
- **WARRANTY** : 12 months part only warranty from installation or 15 months part only warranty from shipment date

## ED5-N-C MODELS SPECIFICATIONS

(unit : inch)

PLAN VIEW

### PHYSICAL DATA

(unit : inch)

Case	L (cabinet only)	T (include end panel)*	A
4' case	48-1/16 (1221mm)	51-5/16 (1301mm)	24 (610mm)
6' case	72-1/8 (1831.5mm)	75-3/8 (1911.5mm)	45-9/16 (1157mm)
8' case	96-1/8 (2442mm)	99-3/8 (2522mm)	55-15/16 (1421mm)
12' case	144-3/16 (3663mm)	147-7/16 (3743mm)	80 (2031.5mm)

\* Adding left & right end panels increases the overall cabinet length on the open multi deck merchandisers by 3-2/8"

Drain Pipe (in)	Liquid Line (in)	Suction Line (in)
SCH 40PVC PIPE	3/8	7/8

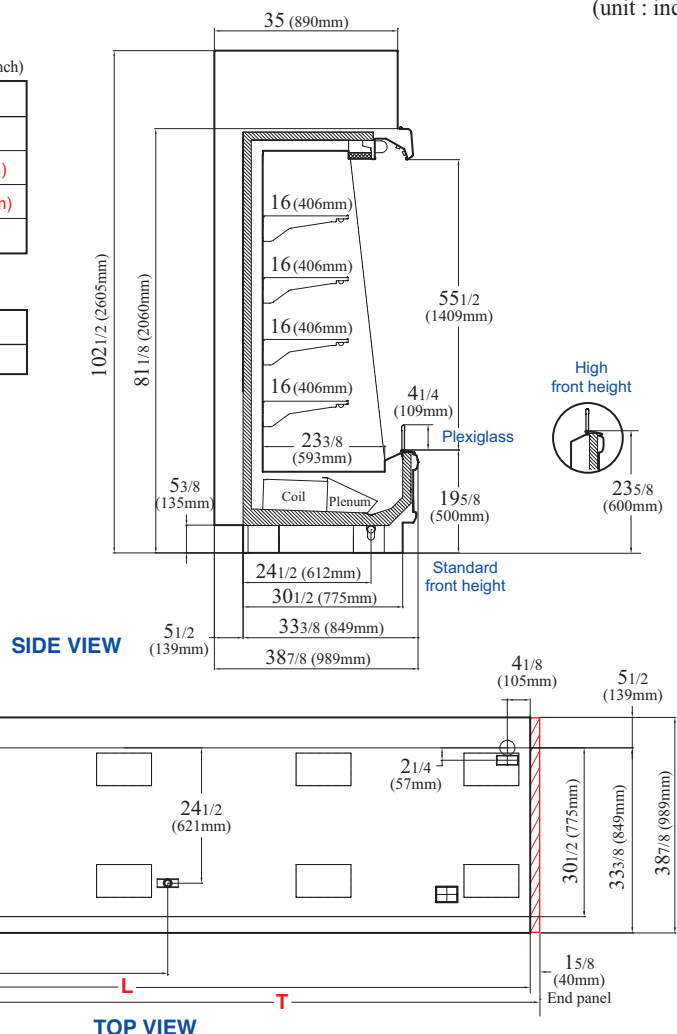

# REACH-IN GLASS DOOR MERCHANDISERS



## ≡ FEATURES & BENEFITS ≡

- *LED lighting system standard*
- *ECM energy-efficient fan motors standard*
- *TEXAKING merchandisers for sale in the United States meet or exceed DOE 2017 energy efficiency standards*
- *Bottom-mounted copper coil and lift-up fan duct with easily removable fan bracket and motor assembly for ease of maintenance*
- *Stainless steel seamless bottom liner provides corrosion resistant and enhanced sanitation*

# REACH-IN GLASS DOOR FREEZERS

## ELECTRICAL DATA

		2 door	3 door	4 door	5 door
Fans (120V)	Fans Per Case	2	3	4	5
	Amps	0.3	0.45	0.6	0.75
	Watts	36	54	72	90

## LIGHTING DATA (120V)

LED Lighting		2 door	3 door	4 door	5 door
Anthony OptiMax Pro (Low Power)	Amps	0.30	0.45	0.60	0.75
	Watts	36	54	72	90

## REFRIGERATION DATA

	Frozen Food		Ice cream	
Evaporator (°F)	-7		-15	
Discharge Air (°F)	-3		-10	
Superheat Set Point at Bulb (°F)	3~5		3~5	
BTUH/door	Parallel	Conventional	Parallel	Conventional
	960	1000	1040	1080

## STANDARD OPTIONS

- Available in 2, 3, 4 and 5 door models
- Available shelf sizes: 18", 20", 22", 24" and 27"
- Square ends with various interior finishes
- Black or white interior, custom painted exterior
- Glass door finishes available in polished aluminum, silver satin or black

## DEFROST DATA (208V)

		2 door	3 door	4 door	5 door
Defrost Heaters (208V)	Amps	6.6	9.8	12.8	19.8
	Watts	1370	2055	2737	4105
Electric	Frequency (Hr)	24			
	Fail-Safe (Min)	45			

## ANTI-SWEAT DOOR HEATER DATA (120V)

		2 door	3 door	4 door	5 door
Anthony (ELM II)	Amps	1.79	2.51	3.27	4.06
	Watts	215	301	392	487

## PHYSICAL DATA

(unit : inch)

Case	L (cabinet only)	T (include end panel)*	A
2 Door	62 (1575mm)	66-1/4 (1683mm)	31 (787mm)
3 Door	92-7/16 (2348mm)	96-11/16 (2456mm)	54-1/8 (1374mm)
4 Door	122-7/8 (3121mm)	127-1/8 (3229mm)	69-5/16 (1760mm)
5 Door	153-5/16 (3894mm)	157-9/16 (4002mm)	84-1/2 (2147mm)

\* Adding left & right end panels increases the overall cabinet length on the merchandisers by 4-2/8"

Drain Pipe (in)	Liquid Line (in)	Suction Line (in)
SCH 40PVC PIPE	3/8	7/8

These Merchandisers are designed for use in stores when temperature and humidity do not exceed 75°F and 55% RH Design and specifications subject to change without notice.

- **WARRANTY :** 12 months part only warranty from installation or 15 months part only warranty from shipment date

## RF MODELS SPECIFICATIONS

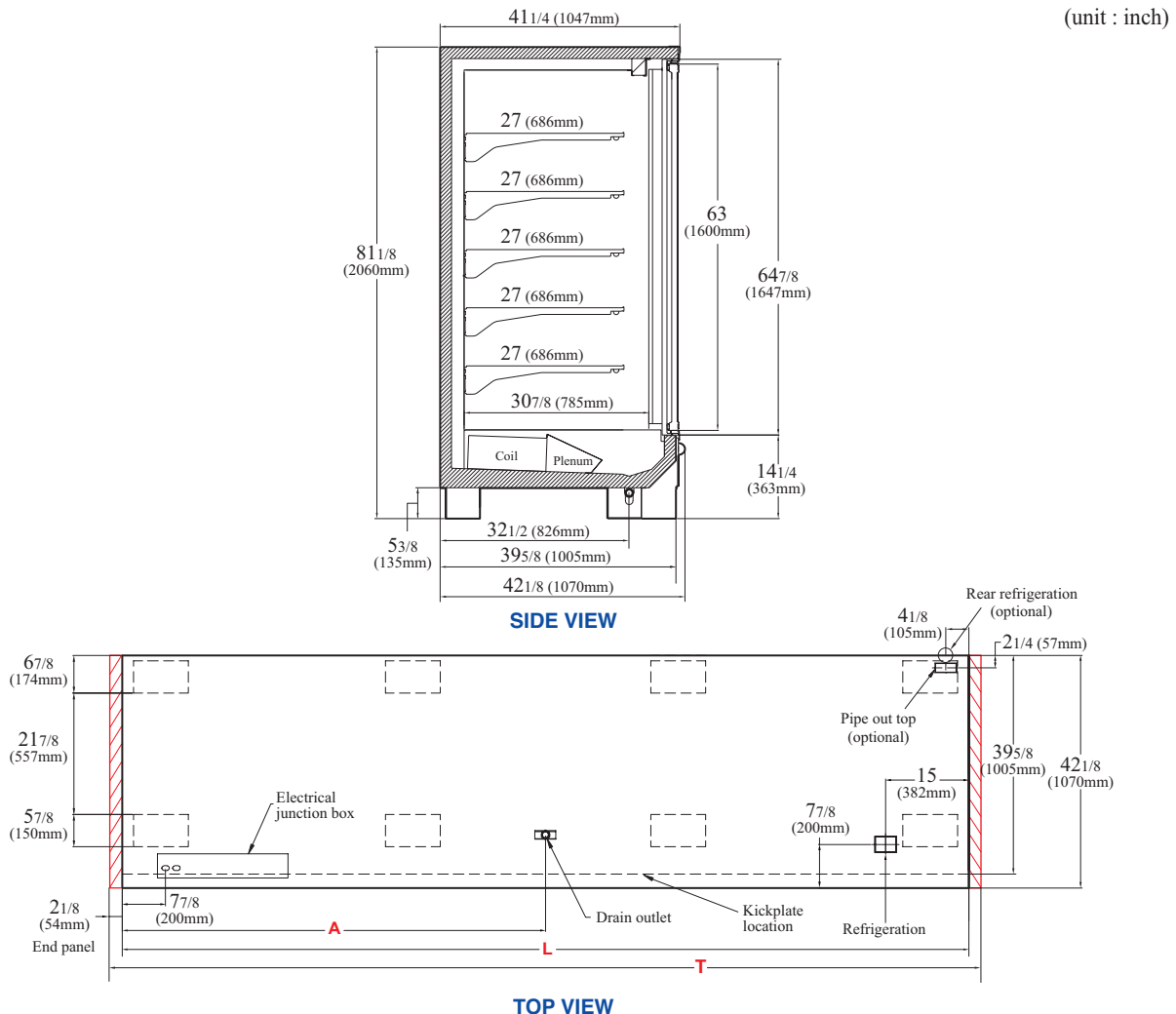

# REACH-IN GLASS DOOR FREEZERS - NARROW

## ELECTRICAL DATA

		2 door	3 door	4 door	5 door
Fans (120V)	Fans Per Case	2	3	4	5
	Amps	0.3	0.45	0.6	0.75
	Watts	36	54	72	90

## LIGHTING DATA (120V)

LED Lighting		2 door	3 door	4 door	5 door
Anthony OptiMax Pro (Low Power)	Amps	0.30	0.45	0.60	0.75
	Watts	36	54	72	90

## REFRIGERATION DATA

	Frozen Food		Ice cream	
Evaporator (°F)	-7		-15	
Discharge Air (°F)	-3		-10	
Superheat Set Point at Bulb (°F)	3~5		3~5	
BTUH/door	Parallel	Conventional	Parallel	Conventional
	960	1000	1040	1080

## STANDARD OPTIONS

- Available in 2, 3, 4 and 5 door models
- Available shelf sizes: 18", 20"
- Square ends with various interior finishes
- Black or white interior, custom painted exterior
- Glass door finishes available in polished aluminum, silver satin or black

## DEFROST DATA (208V)

		2 door	3 door	4 door	5 door
Defrost Heaters (208V)	Amps	6.6	9.8	12.8	19.8
	Watts	1370	2055	2737	4105
Electric	Frequency (Hr)	24			
	Fail-Safe (Min)	45			

## ANTI-SWEAT DOOR HEATER DATA (120V)

		2 door	3 door	4 door	5 door
Anthony (ELM II)	Amps	1.79	2.51	3.27	4.06
	Watts	215	301	392	487

## PHYSICAL DATA

(unit : inch)

Case	L (cabinet only)	T (include end panel)*	A
2 Door	62 (1575mm)	66-1/4 (1683mm)	31 (787mm)
3 Door	92-7/16 (2348mm)	96-11/16 (2456mm)	54-1/8 (1374mm)
4 Door	122-7/8 (3121mm)	127-1/8 (3229mm)	69-5/16 (1760mm)
5 Door	153-5/16 (3894mm)	157-9/16 (4002mm)	84-1/2 (2147mm)

\* Adding left & right end panels increases the overall cabinet length on the merchandisers by 4-2/8"

Drain Pipe (in)	Liquid Line (in)	Suction Line (in)
SCH 40PVC PIPE	3/8	7/8

These Merchandisers are designed for use in stores when temperature and humidity do not exceed 75°F and 55% RH. Design and specifications subject to change without notice.

- WARRANTY** : 12 months part only warranty from installation or 15 months part only warranty from shipment date

## RF-N MODELS SPECIFICATIONS

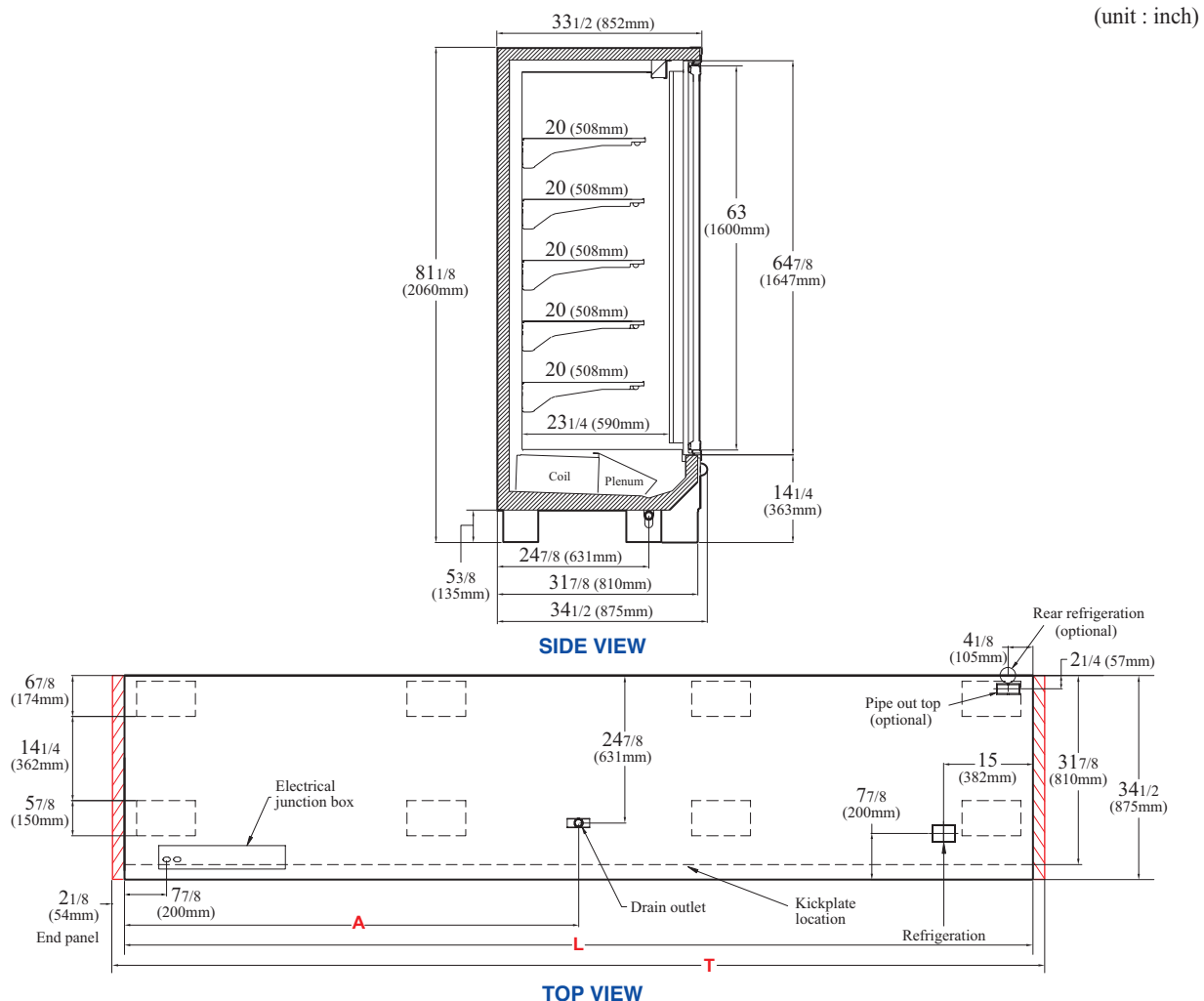

PLAN VIEW

# REACH-IN GLASS DOOR COOLERS

## ELECTRICAL DATA

		2 door	3 door	4 door	5 door
Fans (120V)	Fans Per Case	2	3	4	5
	Amps	0.3	0.45	0.6	0.75
	Watts	36	54	72	90

## LIGHTING DATA (120V)

LED Lighting		2 door	3 door	4 door	5 door
Anthony OptiMax Pro	Amps	0.30	0.45	0.60	0.75
	Watts	36	54	72	90

## REFRIGERATION DATA

		Medium Temp	
Evaporator (°F)		28	
Discharge Air (°F)		33	
Superheat Set Point at Bulb (°F)		3-5	
BTUH/door	Parallel	675	715
	Conventional		715

## STANDARD OPTIONS

- Available in 2, 3, 4 and 5 door models
- Available shelf sizes: 18", 20", 22", 24" and 27"
- Square ends with various interior finishes
- Black or white interior, custom painted exterior
- Glass door finishes available in polished aluminum, silver satin or black

## ANTI CONDENSATE HEATER DATA (120V)

		2 door	3 door	4 door	5 door
Anthony (ELM)	Amps	0.56	0.82	1.09	1.37
	Watts	67	98	131	164

## DEFROST DATA

Type	Timed-off
Frequency (Hr)	4

## PHYSICAL DATA

(unit : inch)

Case	L (cabinet only)	T (include end panel)*	A
2 Door	62 (1575mm)	66-1/4 (1683mm)	31 (787mm)
3 Door	92-7/16 (2348mm)	96-11/16 (2456mm)	54-1/8 (1374mm)
4 Door	122-7/8 (3121mm)	127-1/8 (3229mm)	69-5/16 (1760mm)
5 Door	153-5/16 (3894mm)	157-9/16 (4002mm)	84-1/2 (2147mm)

\* Adding left & right end panels increases the overall cabinet length on the merchandisers by 4-2/8"

Drain Pipe (in)	Liquid Line (in)	Suction Line (in)
SCH 40PVC PIPE	3/8	7/8

These Merchandisers are designed for use in stores when temperature and humidity do not exceed 75°F and 55% RH. Design and specifications subject to change without notice.

- WARRANTY :** 12 months part only warranty from installation or 15 months part only warranty from shipment date

## RM MODELS SPECIFICATIONS

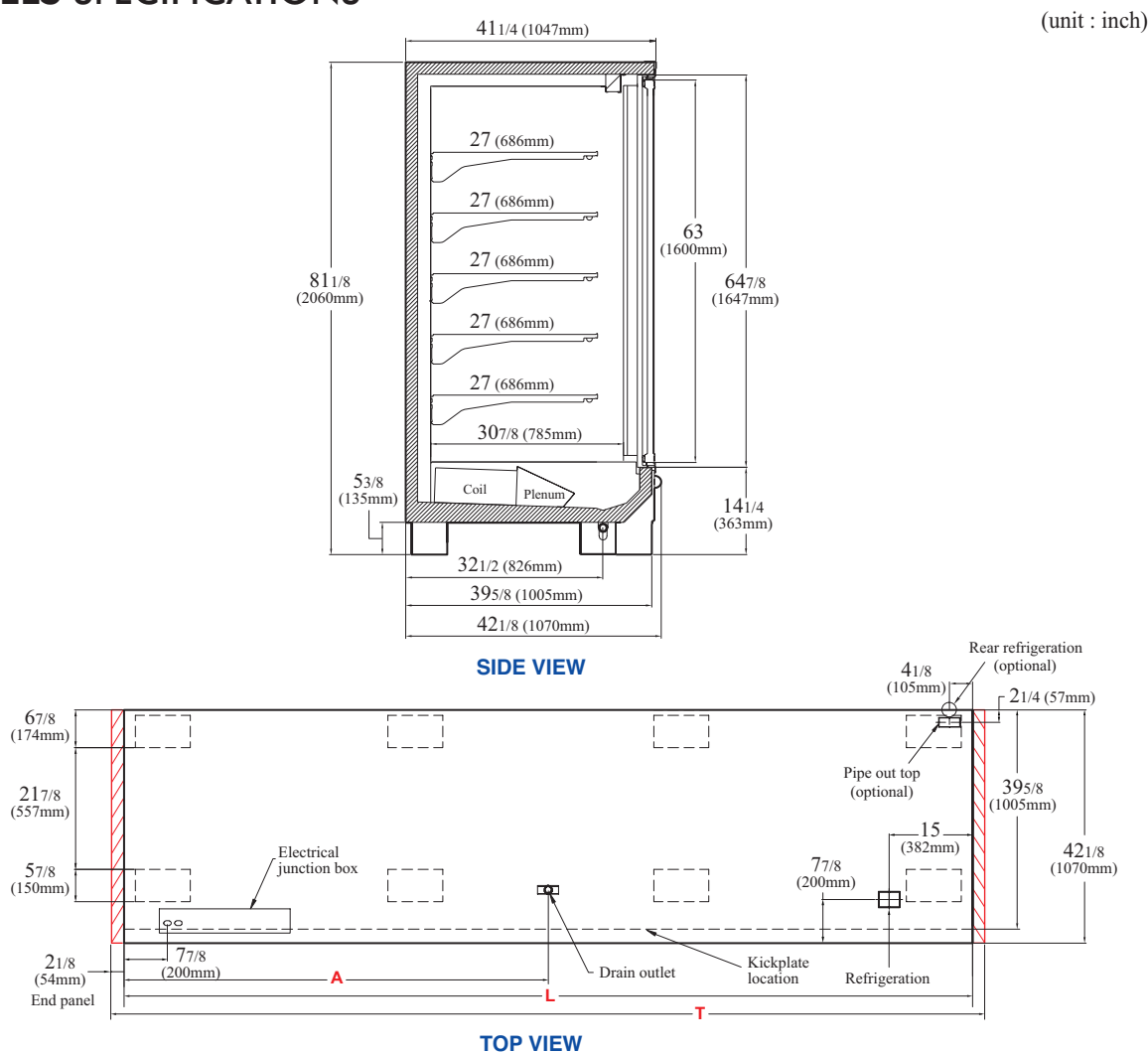

# REACH-IN GLASS DOOR COOLERS - NARROW

## ELECTRICAL DATA

		2 door	3 door	4 door	5 door
Fans (120V)	Fans Per Case	2	3	4	5
	Amps	0.3	0.45	0.6	0.75
	Watts	36	54	72	90

## LIGHTING DATA (120V)

LED Lighting		2 door	3 door	4 door	5 door
Anthony OptiMax Pro	Amps	0.30	0.45	0.60	0.75
	Watts	36	54	72	90

## REFRIGERATION DATA

		Medium Temp	
Evaporator (°F)		28	
Discharge Air (°F)		33	
Superheat Set Point at Bulb (°F)		3-5	
BTUH/door	Parallel	675	715
	Conventional		715

## STANDARD OPTIONS

- Available in 2, 3, 4 and 5 door models
- Available shelf sizes: 18", 20"
- Square ends with various interior finishes
- Black or white interior, custom painted exterior
- Glass door finishes available in polished aluminum, silver satin or black

## ANTI CONDENSATE HEATER DATA (120V)

		2 door	3 door	4 door	5 door
Anthony (ELM)	Amps	0.56	0.82	1.09	1.37
	Watts	67	98	131	164

## DEFROST DATA

Type	Timed-off
Frequency (Hr)	4

## PHYSICAL DATA

(unit : inch)

Case	L (cabinet only)	T (include end panel)*	A
2 Door	62 (1575mm)	66-1/4 (1683mm)	31 (787mm)
3 Door	92-7/16 (2348mm)	96-11/16 (2456mm)	54-1/8 (1374mm)
4 Door	122-7/8 (3121mm)	127-1/8 (3229mm)	69-5/16 (1760mm)
5 Door	153-5/16 (3894mm)	157-9/16 (4002mm)	84-1/2 (2147mm)

\* Adding left & right end panels increases the overall cabinet length on the merchandisers by 4-2/8"

Drain Pipe (in)	Liquid Line (in)	Suction Line (in)
SCH 40PVC PIPE	3/8	7/8

These Merchandisers are designed for use in stores when temperature and humidity do not exceed 75°F and 55% RH. Design and specifications subject to change without notice.

- WARRANTY :** 12 months part only warranty from installation or 15 months part only warranty from shipment date

## RM-N MODELS SPECIFICATIONS

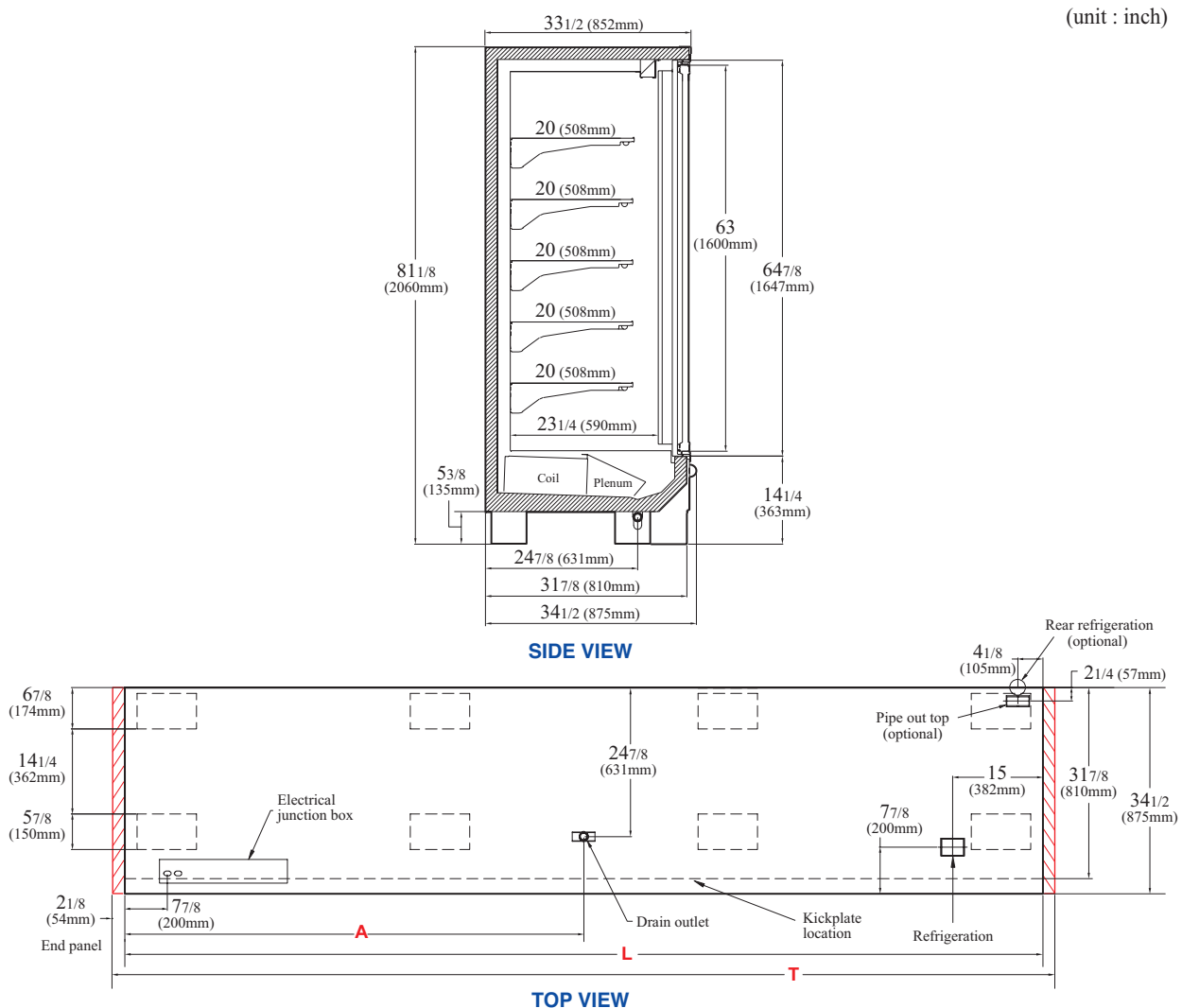



# TOP FIELD MOUNTED CONDENSING UNIT REACH-IN GLASS DOOR MERCHANDISERS



## ≡ FEATURES & BENEFITS ≡

- **LED lighting system standard**
- **ECM energy-efficient fan motors standard**
- **Bottom-mounted copper coil and lift-up fan duct with easily removable fan bracket and motor assembly for ease of maintenance**
- **Stainless steel seamless bottom liner provides corrosion resistant and enhanced sanitation**
- **Top field mounted condensing unit**
- **TEXAKING merchandisers for sale in the United States meet or exceed DOE 2017 energy efficiency standards**
- Easy condensing unit installation: Refrigeration lines are pre-charged and pre-piped to top of case with quick-connect
- No drains required: condensate removal system with field installed pump and condensation pan
- Pre-wired to simplify electrical connections

# REACH-IN GLASS DOOR FREEZERS

## ELECTRICAL DATA

		2 door	3 door	4 door	5 door
Fans (120V)	Fans Per Case	2	3	4	5
	Amps	0.3	0.45	0.6	0.75
	Watts	36	54	72	90

## LIGHTING DATA (120V)

LED Lighting		2 door	3 door	4 door	5 door
Anthony OptiMax Pro (Low Power)	Amps	0.30	0.45	0.60	0.75
	Watts	36	54	72	90

## REFRIGERATION DATA

	Frozen Food		Ice cream	
Evaporator (°F)	-7		-15	
Discharge Air (°F)	-3		-10	
Superheat Set Point at Bulb (°F)	3~5		3~5	
BTUH/door	Parallel	Conventional	Parallel	Conventional
	960	1000	1040	1080

## CONDENSING UNIT

	2 Door	3 Door	4 Door	5 Door
Condensing Unit Model	FFAP-015Z-CFV-072	FFAP-022Z-CFV-071	FFAP-022Z-CFV-071	FFAP-022Z-CFV-071
Refrigerant Charge (R-404A, lbs)	6.0	6.5	8.0	9.4
Electrical Rating	115V/208V-1PH-60HZ : Red & Black Power, White Neutral, Green Ground			
MOCP (Amps) <sup>1</sup>	30	40	40	45
MCA (Amps) <sup>2</sup>	21.4	29.5	31.6	32.9

These Merchandisers are designed for use in stores when temperature and humidity do not exceed.

75°F and 55% RH. Design and specifications subject to change without notice.

1) MOCP : Maximum over - current protection, Including condensing unit and condensate removal system.

2) MCA : Minimum circuit ampacity, Including condensing unit and condensate removal system.

## DEFROST DATA (208V)

		2 door	3 door	4 door	5 door
Defrost Heaters (208V)	Amps	6.6	9.8	12.8	19.8
	Watts	1370	2055	2737	4105
Electric	Frequency (Hr)	24			
	Fail-Safe (Min)	45			

## ANTI CONDENSATE HEATER DATA (120V)

		2 door	3 door	4 door	5 door
Anthony (ELM II)	Amps	1.79	2.51	3.27	4.06
	Watts	215	301	392	487

## STANDARD OPTIONS

- Available in 2, 3, 4 and 5 door models
- Available shelf sizes: 18", 20", 22", 24" and 27"
- Square ends with various interior finishes
- Black or white interior, custom painted exterior
- Glass door finishes available in polished aluminum, silver satin or black

- **WARRANTY** : 12 months part only warranty from installation or 15 months part only warranty from shipment date

## RF-C MODELS SPECIFICATIONS

### PHYSICAL DATA

(unit : inch)

Case	L (cabinet only)	T (include end panel)*	A
2 Door	62 (1575mm)	66-1/4 (1683mm)	31 (787mm)
3 Door	92-7/16 (2348mm)	96-11/16 (2456mm)	54-1/8 (1374mm)
4 Door	122-7/8 (3121mm)	127-1/8 (3229mm)	69-5/16 (1760mm)
5 Door	153-5/16 (3894mm)	157-9/16 (4002mm)	84-1/2 (2147mm)

\* Adding left & right end panels increases the overall cabinet length on the reach in glass door merchandisers by 4-2/8"

Drain Pipe (in)	Liquid Line (in)	Suction Line (in)
SCH 40PVC PIPE	3/8	7/8

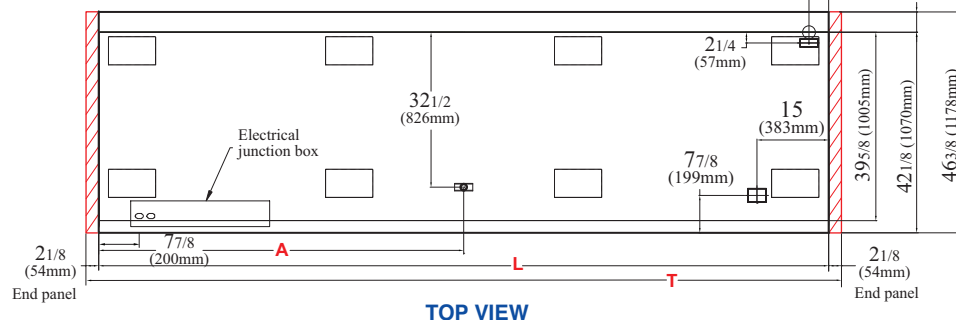
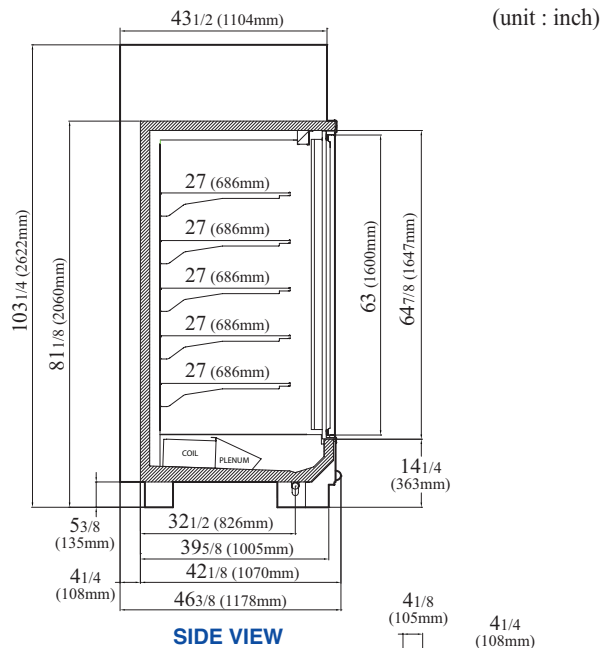

PLAN VIEW

# REACH-IN GLASS DOOR FREEZERS - NARROW

## ELECTRICAL DATA

		2 door	3 door	4 door	5 door
Fans (120V)	Fans Per Case	2	3	4	5
	Amps	0.3	0.45	0.6	0.75
	Watts	36	54	72	90

## LIGHTING DATA (120V)

LED Lighting		2 door	3 door	4 door	5 door
Anthony OptiMax Pro (Low Power)	Amps	0.30	0.45	0.60	0.75
	Watts	36	54	72	90

## REFRIGERATION DATA

	Frozen Food		Ice cream	
Evaporator (°F)	-7		-15	
Discharge Air (°F)	-3		-10	
Superheat Set Point at Bulb (°F)	3~5		3~5	
BTUH/door	Parallel	Conventional	Parallel	Conventional
	960	1000	1040	1080

## CONDENSING UNIT

	2 Door	3 Door	4 Door	5 Door
Condensing Unit Model	FFAP-015Z-CFV-072	FFAP-022Z-CFV-071	FFAP-022Z-CFV-071	FFAP-022Z-CFV-071
Refrigerant Charge (R-404A, lbs)	6.0	6.5	8.0	9.4
Electrical Rating	115V/208V-1PH-60HZ : Red & Black Power, White Neutral, Green Ground			
MOCP (Amps) <sup>1</sup>	30	40	40	45
MCA (Amps) <sup>2</sup>	21.4	29.5	31.6	32.9

These Merchandisers are designed for use in stores when temperature and humidity do not exceed 75°F and 55% RH. Design and specifications subject to change without notice.

1) MOCP : Maximum over - current protection, Including condensing unit and condensate removal system.  
2) MCA : Minimum circuit ampacity, Including condensing unit and condensate removal system.

## DEFROST DATA (208V)

		2 door	3 door	4 door	5 door
Defrost Heaters (208V)	Amps	6.6	9.8	12.8	19.8
	Watts	1370	2055	2737	4105
Electric	Frequency (Hr)	24			
	Fail-Safe (Min)	45			

## ANTI CONDENSATE HEATER DATA (120V)

		2 door	3 door	4 door	5 door
Anthony (ELM II)	Amps	1.79	2.51	3.27	4.06
	Watts	215	301	392	487

## STANDARD OPTIONS

- Available in 2, 3, 4 and 5 door models
- Available shelf sizes: 18", 20"
- Square ends with various interior finishes
- Black or white interior, custom painted exterior
- Glass door finishes available in polished aluminum, silver satin or black

- WARRANTY :** 12 months part only warranty from installation or 15 months part only warranty from shipment date

## RF-N-C MODELS SPECIFICATIONS

### PHYSICAL DATA

(unit : inch)

Case	L (cabinet only)	T (include end panel)*	A
2 Door	62 (1575mm)	66-1/4 (1683mm)	31 (787mm)
3 Door	92-7/16 (2348mm)	96-11/16 (2456mm)	54-1/8 (1374mm)
4 Door	122-7/8 (3121mm)	127-1/8 (3229mm)	69-5/16 (1760mm)
5 Door	153-5/16 (3894mm)	157-9/16 (4002mm)	84-1/2 (2147mm)

\* Adding left & right end panels increases the overall cabinet length on the reach in glass door merchandisers by 4-2/8"

Drain Pipe (in)	Liquid Line (in)	Suction Line (in)
SCH 40PVC PIPE	3/8	7/8

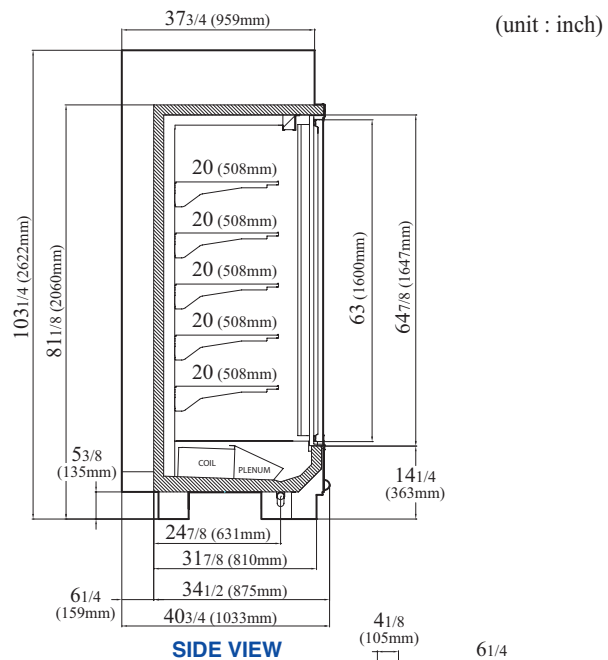

PLAN VIEW

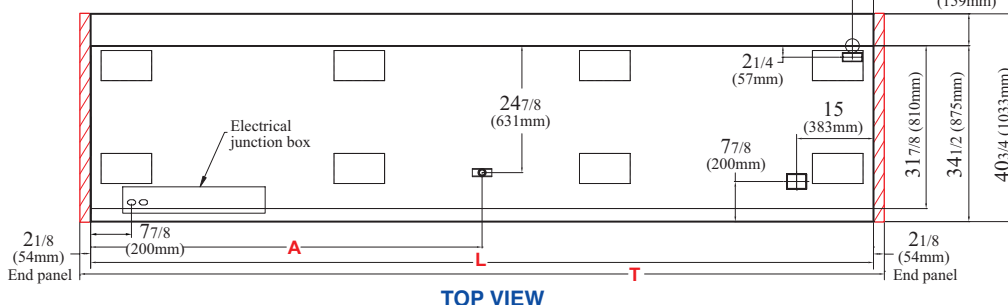



# REACH-IN GLASS DOOR COOLERS - NARROW

## ELECTRICAL DATA

		2 door	3 door	4 door	5 door
Fans (120V)	Fans Per Case	2	3	4	5
	Amps	0.3	0.45	0.6	0.75
	Watts	36	54	72	90

## LIGHTING DATA (120V)

LED Lighting		2 door	3 door	4 door	5 door
Anthony OptiMax Pro	Amps	0.30	0.45	0.60	0.75
	Watts	36	54	72	90

## REFRIGERATION DATA

		Medium Temp	
Evaporator (°F)		28	
Discharge Air (°F)		33	
Superheat Set Point at Bulb (°F)		3-5	
BTUH/door	Parallel	675	715
	Conventional		

## CONDENSING UNIT

	2 Door	3 Door	4 Door	5 Door
Condensing Unit Model	FFAP-015Z-CFV-072	FFAP-015Z-CFV-072	FFAP-015Z-CFV-072	FFAP-015Z-CFV-072
Refrigerant Charge (R-404A, lbs)	3.5	4.0	5.5	5.5
Electrical Rating	115V/208V-1PH-60HZ : Red & Black Power, White Neutral, Green Ground			
MOCP (Amps) <sup>1</sup>	25	25	30	30
MCA (Amps) <sup>2</sup>	19.5	19.5	21.8	22.4

These Merchandisers are designed for use in stores when temperature and humidity do not exceed 75°F and 55% RH. Design and specifications subject to change without notice.

1) MOCP : Maximum over - current protection, Including condensing unit and condensate removal system.

2) MCA : Minimum circuit ampacity, Including condensing unit and condensate removal system.

## ANTI CONDENSATE HEATER DATA (120V)

		2 door	3 door	4 door	5 door
Anthony (ELM)	Amps	0.56	0.82	1.09	1.37
	Watts	67	98	131	164

## DEFROST DATA

Type	Timed-off
Frequency (Hr)	4

## STANDARD OPTIONS

- Available in 2, 3, 4 and 5 door models
- Available shelf sizes: 18", 20"
- Square ends with various interior finishes
- Black or white interior, custom painted exterior
- Glass door finishes available in polished aluminum, silver satin or black
- WARRANTY** : 12 months part only warranty from installation or 15 months part only warranty from shipment date

## RM-N-C MODELS SPECIFICATIONS

### PHYSICAL DATA

(unit : inch)

Case	L (cabinet only)	T (include end panel)*	A
2 Door	62 (1575mm)	66-1/4 (1683mm)	31 (787mm)
3 Door	92-7/16 (2348mm)	96-11/16 (2456mm)	54-1/8 (1374mm)
4 Door	122-7/8 (3121mm)	127-1/8 (3229mm)	69-5/16 (1760mm)
5 Door	153-5/16 (3894mm)	157-9/16 (4002mm)	84-1/2 (2147mm)

\* Adding left & right end panels increases the overall cabinet length on the reach in glass door merchandisers by 4-2/8"

Drain Pipe (in)	Liquid Line (in)	Suction Line (in)
SCH 40PVC PIPE	3/8	7/8

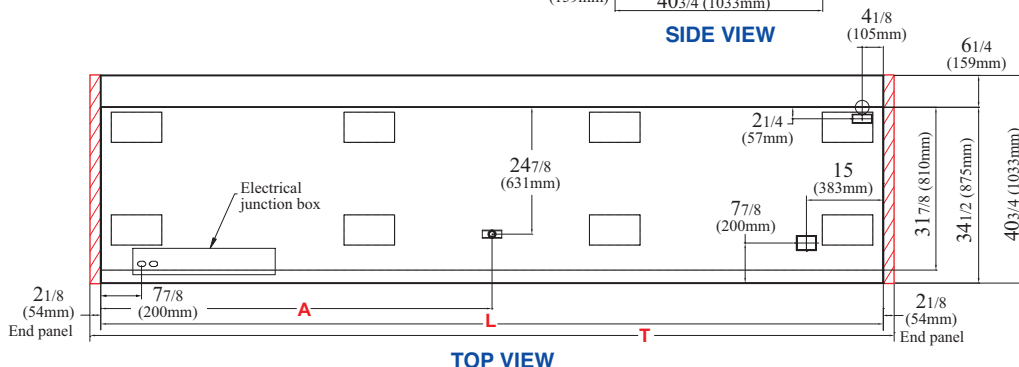
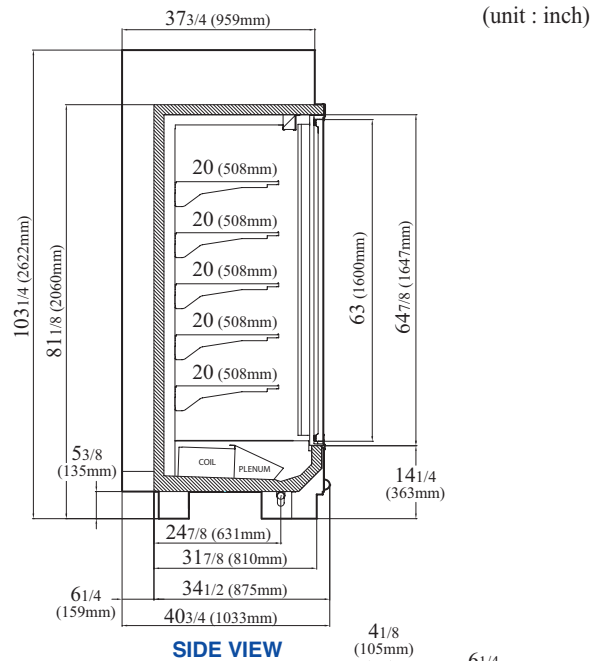

PLAN VIEW



# SELF-SERVE SINGLE DECK MERCHANDISERS



## ≡ FEATURES & BENEFITS ≡

- *Stainless steel interior*
- *Painted metal exterior with stainless steel trim*
- *Solar digital thermometer*
- *Bottom-mounted copper coil and lift-up fan duct with easily removable fan bracket and motor assembly for ease of maintenance*
- *Stainless steel seamless bottom liner provides corrosion resistant and enhanced sanitation*
- *TEXAKING display cases for sale in the United States meet or exceed DOE 2017 energy efficiency standards*

# SELF-SERVE SINGLE DECK MERCHANDISERS

## ELECTRICAL DATA

Fans	4'	6'	8'	12'
Fans Per Case	1	2	2	3
Volts	120	120	120	120
Amps	0.15	0.30	0.30	0.45
Watts	18	36	36	54
Anti-sweat Heater	NA	NA	NA	NA

## DEFROST DATA

Type	Timed-Off
Frequency (Hr)	8
Failsafe (Min)	90
Defrost Thermostat	Close on rise: close 43F, open 33F

## PHYSICAL DATA

(unit : inch)

Case	L (cabinet only)	T (include end panel)*	A
4' case	48-1/16 (1221mm)	51-5/16 (1301mm)	24 (610mm)
6' case	72-1/8 (1831.5mm)	75-3/8 (1911.5mm)	43-15/16 (1115mm)
8' case	96-1/8 (2442mm)	99-3/8 (2522mm)	55-15/16 (1421mm)
12' case	144-3/16 (3663mm)	147-7/16 (3743mm)	80 (2031.5mm)

\* Adding left & right end panels increases the overall cabinet length on the open multi deck merchandisers by 3-2/8"

Drain Pipe (in)	Liquid Line (in)	Suction Line (in)
SCH 40PVC PIPE	3/8	1/2

These Merchandisers are designed for use in stores when temperature and humidity do not exceed 75°F and 55% RH. Design and specifications subject to change without notice.

## REFRIGERATION DATA

Evaporator (°F)	20	
Discharge Air (°F)	27	
Superheat Set Point at Bulb (°F)	6-8	
BTUH/ft	Parallel	Conventional
	500	530

## STANDARD OPTIONS

■ Available length: 4', 6', 8' and 12'

■ **WARRANTY** : 12 months part only warranty from installation or 15 months part only warranty from shipment date

## ED1 MODEL SPECIFICATIONS

(unit : inch)

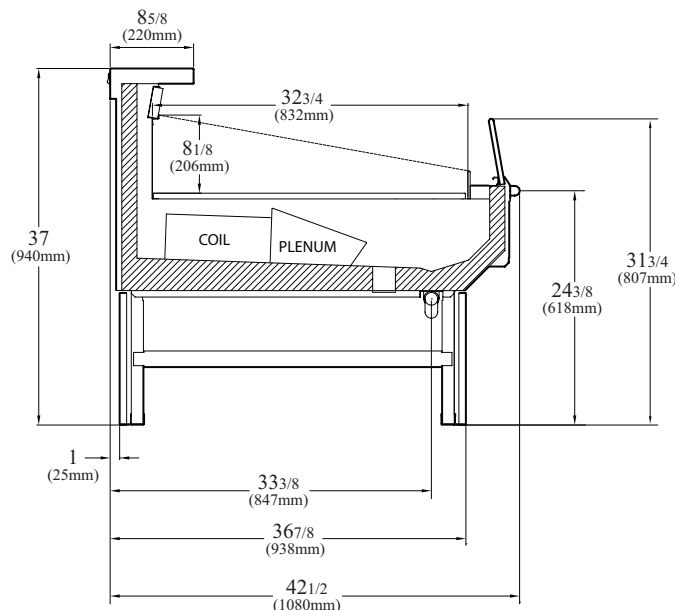

SIDE VIEW

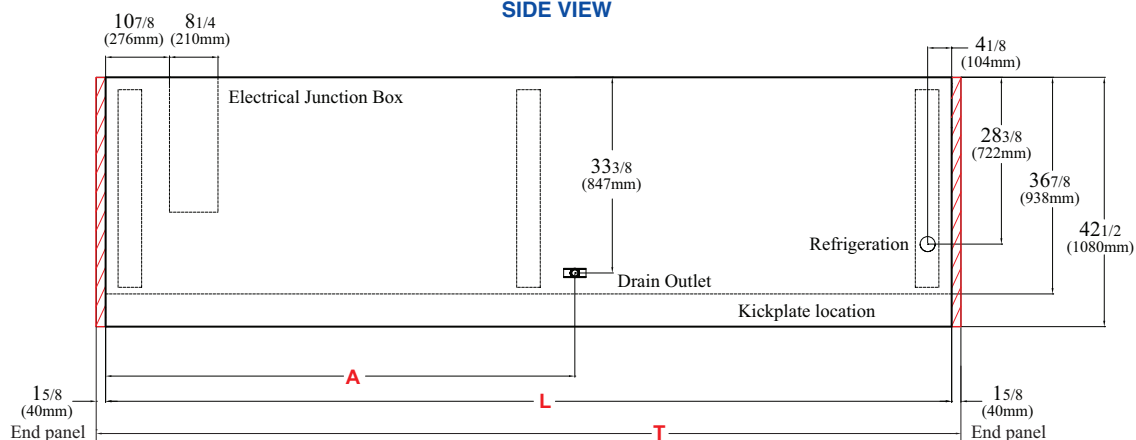

TOP VIEW

PLAN VIEW

# SERVICE-OVER SINGLE DECK CASES



## ≡ FEATURES & BENEFITS ≡

- *Stainless steel top display surface*
- *Stainless interior*
- *Painted metal exterior with stainless steel trim*
- *7/8" thermopane, flat fixed front full length Low-E glass*
- *Oversized gravity coil*
- *Dual row of LED lighting*
- *Solar digital thermometer*
- *Thermopane rear load sliding doors*
- *Stainless steel seamless bottom liner provides corrosion resistant and enhanced sanitation*
- *TEXAKING display cases for sale in the United States meet or exceed DOE 2017 energy efficiency standards*



# GRAVITY-COIL SERVICE-OVER SINGLE DECK CASES

## ELECTRICAL DATA

Fans	4'	6'	8'	12'
Fans Per Case	NA	NA	NA	NA
Volts	NA	NA	NA	NA
Amps	NA	NA	NA	NA
Watts	NA	NA	NA	NA

## LIGHTING DATA

LED Lighting	4'	6'	8'	12'
Light Length	4'	3'	4'	4'
Amps (2 Rows)	0.16	0.24	0.32	0.48
Watts (2 Rows)	20	32	40	60

These Merchandisers are designed for use in stores when temperature and humidity do not exceed 75°F and 55% RH. Design and specifications subject to change without notice.

## STANDARD OPTIONS

- Available length: 4', 6', 8' and 12'
- Rear flip-up work board
- Scale stand
- Exterior stainless steel finish
- Ice pans
- **WARRANTY** : 12 months part only warranty from installation or 15 months part only warranty from shipment date

## DEFROST DATA

Type	Timed-Off
Frequency (Hr)	24
Failsafe (Min)	90
Defrost Thermostat	Close on rise: close 50F, open 40F

## REFRIGERATION DATA

Evaporator (°F)	22	
Discharge Air (°F)	27	
Superheat Set Point at Bulb (°F)	6~8	
BTUH/ft	Parallel	Conventional
	155	175

## PHYSICAL DATA

(unit : inch)

Case	L (cabinet only)	T (include end panel)*	A
4' case	48-1/16 (1221mm)	51-5/16 (1301mm)	24 (610mm)
6' case	72-1/8 (1831.5mm)	75-3/8 (1911.5mm)	43-15/16 (1115mm)
8' case	96-1/8 (2442mm)	99-3/8 (2522mm)	55-15/16 (1421mm)
12' case	144-3/16 (3663mm)	147-7/16 (3743mm)	80 (2031.5mm)

\* Adding left & right end panels increases the overall cabinet length on the open multi deck merchandisers by 3-2/8"

Drain Pipe (in)	Liquid Line (in)	Suction Line (in)
SCH 40PVC PIPE	3/8	1/2

## SMF-G MODEL SPECIFICATIONS

(unit : inch)

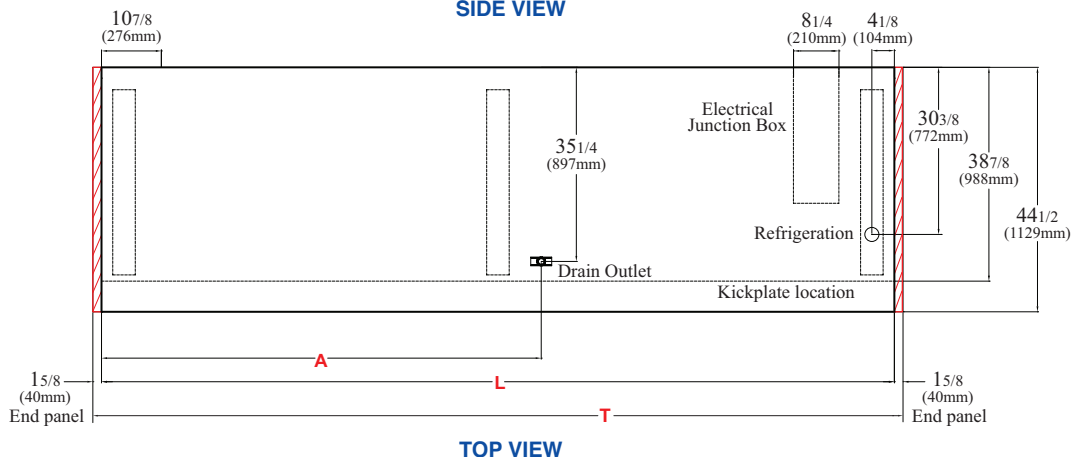
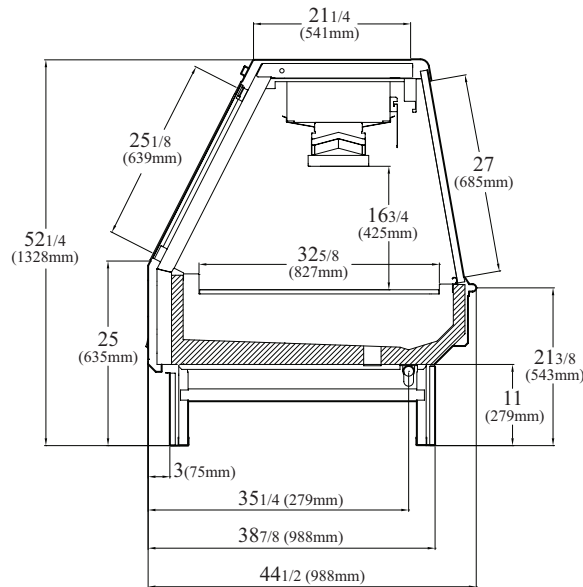

PLAN VIEW



# Refrigeration System

Unit Coolers

Condensing Units

Package Units - SMART 7

# LOW PROFILE UNIT COOLERS



## LOW PROFILE UNIT COOLER STANDARD FEATURES

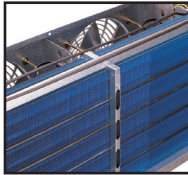

- Blue anti-corrosion-fin increases the life span of the coil.
- Air-pass guard is located at the bottom of the coil to improve heat exchange rate.
- Easy to replace defrost heater (LED model).
- Corrugated fin is used to increase heat exchange rate by expanding the surface area.

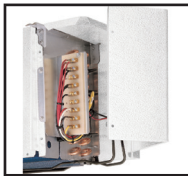

- Even in confined space, all parts can be reached easily by opening the front cover.
- Location of power connector makes replacement of motor convenient.
- **1 Year fan motor and parts warranty!**

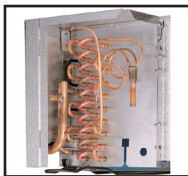

- Seamless inner groove copper tube increases the heat exchange rate by reducing the space between the fin and the copper tube.
- Venturi type distributor and precise orifice hole are used to minimize the pressure drop and maximize the freezing capacity respectively.
- Even in confined space, all parts can be reached easily by opening the front cover.

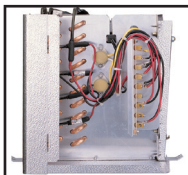

- Thermostat is installed to prevent over temperature on heater.
- Circuit opens automatically over 50°F.
- Parts available: Expansion Valve (Sporlan) (Factory pre-mounted)  
Solenoid Valve (Sporlan) (Factory pre-mounted)  
Thermostat (Johnson control)



- The spiral fan guard enables cold air to be delivered efficiently and thoroughly.
- The protruding fan and motor placement substantially reduce vibration and noise.
- PSC fan motor, which prevents oil evaporation, is used for long life expectancy.
- **EC motor (optional) for high energy efficiency.**



- Unique air flow system (Patent pending) results in improved circulation within crowded walk-in cooler/freezer.
- Anti-oxidizing stainless steel mounting and bolts.

**All Replacement Parts are Universal!**

# LOW PROFILE UNIT COOLERS

## DIMENSIONAL DATA

(Unit : inch)

**TOP VIEW**

**FRONT VIEW**

**SIDE VIEW**

Drain Connection  
3/4" MPT (14NPS)

**... Model Nomenclature**

ADR/LED	042	A/B	E	X
Model Series	Capacity	Voltage	Motor	
ADR= Air Defrost (REF)	Size x 100 = BTU/H	A= 115/1/60	E= EC Motor	X = Expansion valve
LED= Electric Defrost (Low Temperature)		B= 208/230/1/60		M = Expansion valve + Solenoid valve + Temp controller

## DIMENSIONAL DATA FOR ADR/LED MODELS

Air Defrost Models 6 FPI	Electric Defrost Models 6 FPI	No. of Fans	Dimensions (Inches / mm)								Approx. Net Wt. (lbs. / kg)	
			A		B		C		D		ADR	LED
	LED042B	1	29.4	747.4	17.4	443						31 / 14
ADR068A		1	29.4	747.4	17.4	443				34 / 15		
ADR073A		2	45.4	1154.4	33.5	850				45 / 20		
	LED068B	2	45.4	1154.4	33.5	850						49 / 22
ADR109A		2	45.4	1154.4	33.5	850				49 / 22		
	LED082B	2	45.4	1154.4	33.5	850						51 / 23
ADR136A	LED094B	2	45.4	1154.4	33.5	850				53 / 24	53 / 24	
	LED126B	3	61.4	1559.4	49.4	1255						66 / 30
ADR163A	LED147B	3	61.4	1559.4	49.4	1255				66 / 30	72 / 33	
ADR196A		3	61.4	1559.4	49.4	1255				69 / 31		
ADR218A	LED168B	4	77.4	1966.4	65.4	1662				83 / 38	77 / 35	
	LED189B	4	77.4	1966.4	65.4	1662						83 / 38
ADR273A	LED210B	5	93.5	2374.4	81.5	2070				101 / 46	101 / 46	
	LED252B	6	109.5	2782.4	97.6	2478	49.0	1244	48.6	1234		128 / 58
ADR393A	LED300B	6	109.5	2782.4	97.6	2478	49.0	1244	48.6	1234	127 / 57	131 / 59

# LOW PROFILE UNIT COOLERS



## ADR AIR DEFROST MODELS 60HZ. WITH PSC MOTORS.

ADR Model	Capacity BTUH/Watts 10°F TD/6°C TD 25°F SST/-4°C SST		Suction	Fan Data			PSC Motor Data 115V 1Ph 60Hz			EC Motor Data 120V 1Ph 60Hz	
				CFM / m³H	No.	HP	Total Amps	Watts	Total Amps	Watts	
ADR068A*	6825	1995	7/8 ID	650	1104	1	1/15	0.75	80	1.00	50
ADR073A*	7350	2155	7/8 ID	1460	2481	2	1/15	1.50	160	2.00	100
ADR109A*	10920	3205	7/8 ID	1400	2379	2	1/15	1.50	160	2.00	100
ADR136A*	13650	4000	7/8 ID	1300	2209	2	1/15	1.50	160	2.00	100
ADR163A*	16380	4800	7/8 ID	2100	3568	3	1/15	2.25	240	3.00	150
ADR196A*	19600	5740	7/8 ID	1950	3313	3	1/15	2.25	240	3.00	150
ADR218A*	21840	6405	1-1/8 ID	2800	4758	4	1/15	3.00	320	4.00	200
ADR273A*	27300	8000	1-1/8 ID	3250	5522	5	1/15	3.75	400	5.00	250
ADR393A*	39300	11515	1-3/8 ID	3900	6627	6	1/15	4.50	480	6.00	300

\* X: PSC motor TXV mounted \* M: PSC motor TXV, Solenoid mounted \* EX: EC motor, TXV mounted \* EM: EC motor, TXV, Solenoid mounted  
 \* Coil Inlet: 1/2 OD \* External Equalizer: 1/4 OD \* Drain: 3/4 MPT

## LED ELECTRIC DEFROST MODELS 60HZ. WITH PSC MOTORS.

LED Model	Capacity BTUH/Watts 10°F /6°C TD -20°F/-29°C SST		Fan Data			PSC Motor Data 208-230V 1Ph 60Hz			EC Motor Data 230V 1Ph 60Hz		Defrost Heater (Total Amps)			
			CFM / m³H	No.	Suction	HP	Total Amps	Watts	Total Amps	Watts	Watts	230/ 1/60	230/ 3/60	
LED042B*	4200	1230	700	1189	1	5/8 ID	1/15	0.35	80	0.60	50	900	3.9	2.3
LED068B*	6825	1995	1400	2379	2	5/8 ID	1/15	0.70	160	1.20	100	1800	7.8	4.5
LED082B*	8230	2410	1300	2209	2	5/8 ID	1/15	0.70	160	1.20	100	1800	7.8	4.5
LED094B*	9450	2770	1300	2209	2	7/8 ID	1/15	0.70	160	1.20	100	1800	7.8	4.5
LED126B*	12600	3695	2100	3568	3	7/8 ID	1/15	1.05	240	1.80	150	2700	11.7	6.8
LED147B*	14700	4305	1950	3313	3	7/8 ID	1/15	1.05	240	1.80	150	2700	11.7	6.8
LED168B*	16880	4940	2600	4418	4	1-1/8 ID	1/15	1.40	320	2.40	200	3600	15.7	9.0
LED189B*	18900	5545	2600	4418	4	1-1/8 ID	1/15	1.40	320	2.40	200	3600	15.7	9.0
LED210B*	21000	6155	3250	5522	5	1-1/8 ID	1/15	1.75	400	3.00	250	4500	19.6	11.3
LED252B*	25200	7380	3900	6627	6	1-1/8 ID	1/15	2.10	480	3.60	300	5400	23.5	13.6
LED300B*	30030	8800	3900	6627	6	1-1/8 ID	1/15	2.10	480	3.60	300	5400	23.5	13.6

\* X: PSC motor TXV mounted \* M: PSC motor TXV, Solenoid mounted \* EX: EC motor, TXV mounted \* EM: EC motor, TXV, Solenoid mounted  
 \* Coil Inlet: 1/2 OD \* External Equalizer: 1/4 OD \* Drain: 3/4 MPT

# MEDIUM PROFILE UNIT COOLERS

## MEDIUM PROFILE UNIT COOLER STANDARD FEATURES

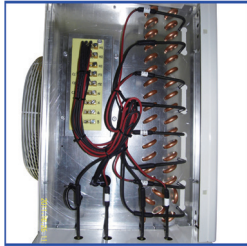

### Feature

- More space in the electrical cavity.
- Electrical board is now facing side for easy installation and servicing.
- All wiring (solenoid and motor) is now located in the bottom of the unit for easy access.
- Charge nipple provided for suction pressure measurement.
- Aluminum cases are now powder coated for corrosion protection.
- FAN GUIDE GRILL provided for air throw extension.
- Drain pan hinged on rear for easy access and applied double drain pan for thermal efficiency.



### Front Access with More Space

- Design features easy front access to both electrical and refrigeration components.
- More space in the electrical cavity makes the unit easier to service and install.
- Side facing electrical control board.

### Wiring

- Solenoid harness is standard.
- Motor and solenoid harnesses are attached to sheet metal panels and are now located at the bottom of the unit for easy access.
- Easy plug connectors for motor harness.



### Heaters & Coil

- Coil heater slots have been enlarged for easier installation and replacement.
- Fixed defrost termination and adjustable defrost cycle on electric defrost (selection).

## Test for Guided Fan Guard

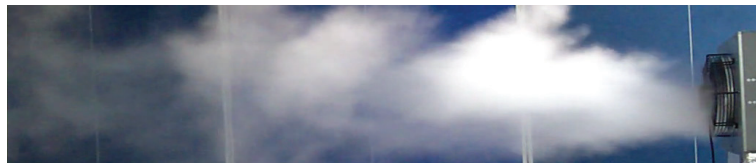

Without Guided Fan Guard distance reach up to 52ft



With Guided Fan Guard distance reach up to 109ft

**All Replacement Parts are Universal!**

# MEDIUM PROFILE UNIT COOLERS

## DIMENSIONAL DATA

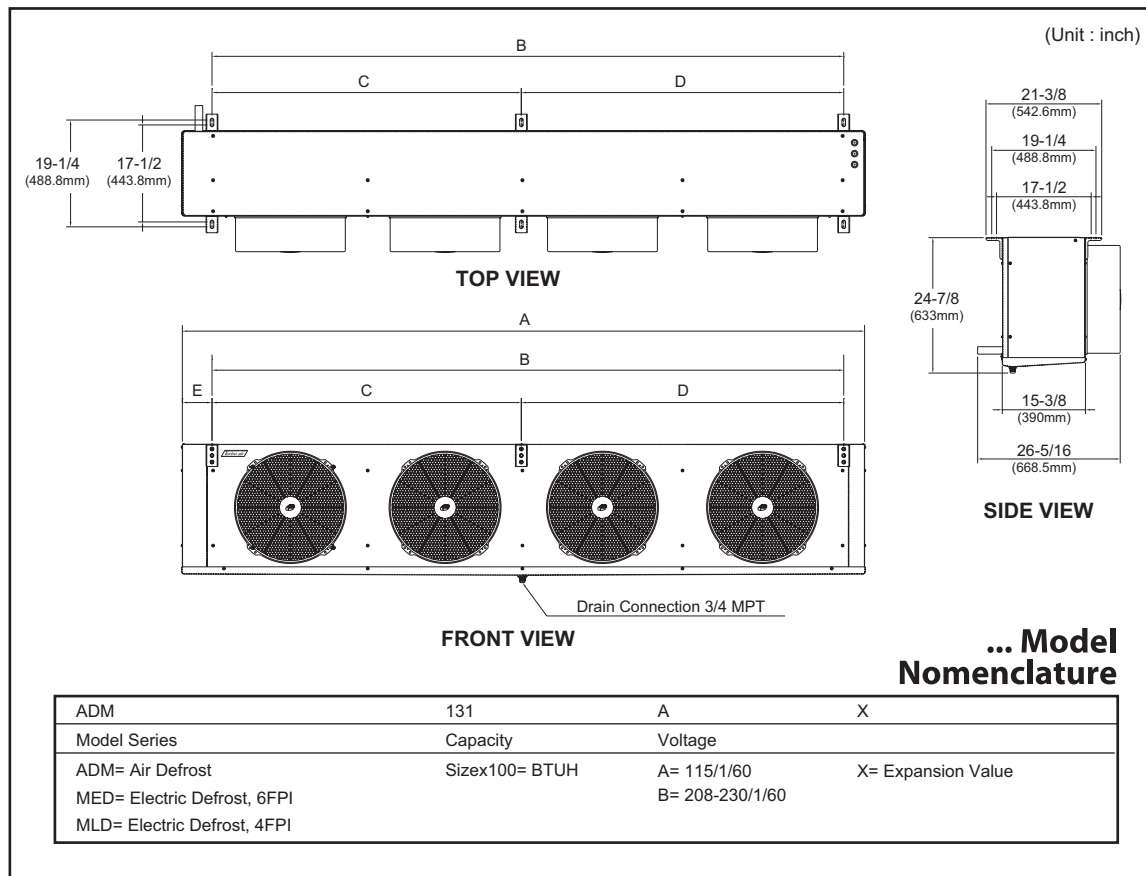

## DIMENSIONAL DATA FOR ADM/MED/MLD MODELS

Air Defrost		Electric Defrost				Dimensions				
						A	B	C	D	E
6 FPI Model	Weight	6 FPI Model	Weight	4 FPI Model	Weight	Inch (mm)	Inch (mm)	Inch (mm)	Inch (mm)	Inch (mm)
ADM131A	75	MED105B	80	-	-	39.4 (1002)	30.3 (770)	-	-	5.4 (136)
ADM162A	82	MED144B	86	MLD103B	82	39.4 (1002)	30.3 (770)	-	-	5.4 (136)
ADM248A	126	MED207B	135	MLD165B	128	67.4 (1712)	58.3 (1480)	-	-	5.4 (136)
ADM321A	139	MED275B	148	MLD220B	139	67.4 (1712)	58.3 (1480)	-	-	5.4 (136)
ADM370A	179	MED317B	190	MLD253B	181	95.4 (2422)	86.2 (2190)	-	-	5.4 (136)
ADM480A	197	MED410B	210	MLD332B	195	95.4 (2422)	86.2 (2190)	-	-	5.4 (136)
ADM567A	254	MED513B	269	MLD388B	250	123.3 (3132)	114.2 (2900)	55.9 (1420)	58.3 (1480)	5.4 (136)
ADM638A	258	MED547B	274	MLD442B	256	123.3 (3132)	114.2 (2900)	55.9 (1420)	58.3 (1480)	5.4 (136)

# MEDIUM PROFILE UNIT COOLERS

## PHYSICAL DATA

### ADM Air Defrost Models 60Hz. With PSC Motors

Model	No. of Fans	Connections (Inches)				Approx. Net Weight	
		Coil Inlet ODF	Suction ODF	External Equalizer ODF	Drain MPT	lbs	kg
ADM131A	1	1/2	7/8	1/4	3/4	75	34
ADM162A	1	1/2	1-1/8	1/4	3/4	82	37
ADM248A	2	7/8	1-1/8	1/4	3/4	126	57
ADM321A	2	7/8	1-1/8	1/4	3/4	139	63
ADM370A	3	7/8	1-3/8	1/4	3/4	179	81
ADM480A	3	7/8*	1-3/8	1/4	3/4	197	89
ADM567A	4	7/8*	1-5/8	1/4	3/4	254	115
ADM638A	4	7/8*	1-5/8	1/4	3/4	258	117

### MED Electric Defrost Models 60Hz. With PSC Motors

Model	No. of Fans	Connections (Inches)				Approx. Net Weight	
		Coil Inlet ODF	Suction ODF	External Equalizer ODF	Drain MPT	lbs	kg
MED105B	1	1/2	7/8	1/4	3/4	80	36
MED144B	1	1/2	7/8	1/4	3/4	86	39
MED207B	2	7/8	1-1/8	1/4	3/4	135	61
MED275B	2	7/8*	1-3/8	1/4	3/4	148	67
MED317B	3	7/8*	1-3/8	1/4	3/4	190	86
MED410B	3	7/8*	1-3/8	1/4	3/4	210	95
MED513B	4	7/8*	1-5/8	1/4	3/4	269	122
MED547B	4	7/8*	1-5/8	1/4	3/4	274	124

### MLD Electric Defrost Models 60Hz. With PSC Motors

Model	No. of Fans	Connections (Inches)				Approx. Net Weight	
		Coil Inlet ODF	Suction ODF	External Equalizer ODF	Drain MPT	lbs	kg
MLD103B	1	1/2	7/8	1/4	3/4	82	37
MLD165B	2	7/8	1-1/8	1/4	3/4	128	58
MLD220B	2	7/8*	1-3/8	1/4	3/4	139	63
MLD253B	3	7/8*	1-3/8	1/4	3/4	181	82
MLD332B	3	7/8*	1-3/8	1/4	3/4	195	88
MLD388B	4	7/8*	1-5/8	1/4	3/4	250	113
MLD442B	4	7/8*	1-5/8	1/4	3/4	256	116

\* Supplied with adapter to 1-1/8" ODF.



# MEDIUM PROFILE UNIT COOLERS

## AIR DEFROST CAPACITIES - 6FPI

ADM Air Defrost Models 60Hz. With PSC Motors

Model	Capacity		No.	Fan Data						PSC Motor Data 60Hz 115V 1Ph		
	10°F TD 25°F SST	6°C TD -4°C SST		Air Volume		Air Throw *				HP	Amps	Watts
	BTUH	Watts		CFM	m³/h	Wire Guard		Axial Guard				
						ft.	m	ft.	m			
ADM131A*	13100	3835	1	2370	4025	43	13	89	27	1/4	3	300
ADM162A*	16200	4745	1	2340	3975	43	13	89	27	1/4	3	300
ADM248A*	24800	7260	2	4740	8050	46	14	95	29	1/4	6	600
ADM321A*	32100	9400	2	4670	7935	46	14	95	29	1/4	6	600
ADM370A*	37000	10835	3	7120	12095	49	15	102	31	1/4	9	900
ADM480A*	48000	14055	3	7010	11910	49	15	102	31	1/4	9	900
ADM567A*	56700	16605	4	9400	15970	52	16	108	33	1/4	12	1200
ADM638A*	63800	18685	4	9350	15885	52	16	108	33	1/4	12	1200

## ELECTRIC DEFROST CAPACITIES - 6FPI

MED Air Defrost Models 60Hz. With PSC Motors

Model	Capacity		No.	Fan Data						PSC Motor Data 60Hz 208~230V 1Ph			Defrost Heater (Total Amps)		
	10°F TD -20°F SST	6°C TD -4°C SST		Air Volume		Air Throw *				HP	Amps	Watts	Watts	230/ 1/60	230/ 3/60
	BTUH	Watts		CFM	m³/h	Wire Guard		Axial Guard							
						ft.	m	ft.	m						
MED105B*	10500	3075	1	2360	4010	39	12	85	26	1/4	1.4	300	2940	12.8	7.4
MED144B*	14400	4215	1	2320	3940	39	12	85	26	1/4	1.4	300	2940	12.8	7.4
MED207B*	20700	6060	2	4710	8000	43	13	92	28	1/4	2.8	600	5340	23.2	13.4
MED275B*	27500	8055	2	4640	7880	43	13	92	28	1/4	2.8	600	5340	23.2	13.4
MED317B*	31700	9285	3	7070	12010	46	14	98	30	1/4	4.2	900	7680	-	19.3
MED410B*	41000	12005	3	6950	11805	46	14	98	30	1/4	4.2	900	7680	-	19.3
MED513B*	51300	15025	4	9350	15885	49	15	105	32	1/4	5.6	1200	10080	-	25.3
MED547B*	54700	16020	4	9260	15730	49	15	105	32	1/4	5.6	1200	10080	-	25.3

## ELECTRIC DEFROST CAPACITIES - 4FPI

MLD Air Defrost Models 60Hz. With PSC Motors

Model	Capacity		No.	Fan Data						PSC Motor Data 60Hz 208~230V 1Ph			Defrost Heater (Total Amps)		
	10°F TD -20°F SST	6°C TD -29°C SST		Air Volume		Air Throw *				HP	Amps	Watts	Watts	230/ 1/60	230/ 3/60
	BTUH	Watts		CFM	m³/h	Wire Guard		Axial Guard							
						ft.	m	ft.	m						
MLD103B*	10300	3015	1	2330	3960	43	13	88	27	1/4	1.4	300	2940	12.8	7.4
MLD165B*	16500	4830	2	4730	8035	46	14	95	29	1/4	2.8	600	5340	23.2	13.4
MLD220B*	22000	6440	2	4660	7915	46	14	95	29	1/4	2.8	600	5340	23.2	13.4
MLD253B*	25300	7410	3	7090	12045	49	15	105	32	1/4	4.2	900	7680	-	19.3
MLD332B*	33200	9720	3	6970	11840	49	15	105	32	1/4	4.2	900	7680	-	19.3
MLD388B*	38800	11360	4	9380	15935	52	16	112	34	1/4	5.6	1200	10080	-	25.3
MLD442B*	44200	12945	4	9290	15785	52	16	112	34	1/4	5.6	1200	10080	-	25.3

\* X: PSC motor TXV mounted \* M: PSC motor TXV, Solenoid mounted \* Air throw is determined the air velocity 50 FPM.

# THIN PROFILE COOLERS

## MODEL NOMENCLATURE

TTA	0 5 6	A
Model Series	Capacity	Voltage
TTA= Air Defrost TTE= Electric Defrost	Size x 100= BTUH	A= 115/1/60 B= 208-230/1/60



## PERFORMANCE DATA & SPECIFICATIONS

### TTA Air Defrost Models 60Hz. With PSC Motors

Model	Capacity		Fan Data			PSC Motor Data					
	10°F TD 25°F SST	6°C TD -4°C SST				115V 1Ph 60Hz			208-230V 1Ph 60Hz		
	BTUH	Watts	CFM	m³H	No.	HP	Total Amps	Total Watts	HP	Total Amps	Total Watts
TTA056A*	5642	1653	953	1619	2	1/15	1.50	160	1/15	0.70	160
TTA084A*	8464	2479	1430	2429	3	1/15	2.25	240	1/15	1.05	240
TTA112A*	11285	3305	1906	3239	4	1/15	3.00	320	1/15	1.40	320
TTA141A*	14106	4131	2383	4048	5	1/15	3.75	400	1/15	1.75	400
TTA175A*	17514	5129	2859	4858	6	1/15	4.50	480	1/15	2.10	480

### TTE Electric Defrost Models 60Hz. With PSC Motors

Model	Capacity		Fan Data			PSC Motor Data 208-230V 1Ph 60Hz			Defrost Heater 208-230V 1Ph 60Hz	
	10°F TD -10°F SST	6°C TD -23°C SST				HP	Total Amps	Total Watts	Total Watts	Total Amps
	BTUH	Watts	CFM	m³H	No.	HP	Total Amps	Total Watts	Total Watts	Total Amps
TTE049B*	4960	1452	953	1619	2	1/15	0.70	160	1100	4.8
TTE074B*	7441	2179	1430	2429	3	1/15	1.05	240	1650	7.2
TTE099B*	9921	2905	1906	3239	4	1/15	1.40	320	2200	9.6
TTE124B*	12402	3632	2383	4048	5	1/15	1.75	400	2750	12.0
TTE138B*	13890	4068	2859	4858	6	1/15	2.10	480	3300	14.4

\* X: PSC motor TXV mounted \* M: PSC motor TXV, Solenoid mounted

# THIN PROFILE COOLERS

## PHYSICAL DATA

### TTA Air Defrost Physical Data

Model	Connections (Inch)					Approx. Net Weight (Lbs. / kg)
	No. of Fans	Coil Inlet	Suction	External Equalizer	Drain	
TTA056A	2	1/2 OD	5/8 ID	1/4 OD	3/4 MPT	44 / 20
TTA084A	3	1/2 OD	5/8 ID	1/4 OD	3/4 MPT	61 / 28
TTA112A	4	1/2 OD	7/8 ID	1/4 OD	3/4 MPT	80 / 36
TTA141A	5	1/2 OD	7/8 ID	1/4 OD	3/4 MPT	97 / 44
TTA175A	6	1/2 OD	1-1/8 ID	1/4 OD	3/4 MPT	115 / 52

### TTE Electric Defrost Physical Data

Model	Connections (Inch)					Approx. Net Weight (Lbs. / kg)
	No. of Fans	Coil Inlet	Suction	External Equalizer	Drain	
TTE049B	2	1/2 OD	5/8 ID	1/4 OD	3/4 MPT	45 / 20
TTE074B	3	1/2 OD	5/8 ID	1/4 OD	3/4 MPT	62 / 28
TTE099B	4	1/2 OD	7/8 ID	1/4 OD	3/4 MPT	81 / 37
TTE124B	5	1/2 OD	7/8 ID	1/4 OD	3/4 MPT	99 / 45
TTE138B	6	1/2 OD	1-1/8 ID	1/4 OD	3/4 MPT	116 / 53

### Dimensional Data For All Models

Air Defrost Models 6 FPI	Electric Defrost Models 6 FPI	No. of Fans	Dimensions (Inch / mm)			
			A	B	C	D
TTA056A	TTE049B	2	49.7 / 1262	40.8 / 1037	- / -	- / -
TTA084A	TTE074B	3	69.4 / 1764	60.6 / 1539	- / -	- / -
TTA112A	TTE099B	4	89.2 / 2266	80.4 / 2041	40.9 / 1038	- / -
TTA141A	TTE124B	5	109.0 / 2768	100.1 / 2543	40.9 / 1038	- / -
TTA175A	TTE138B	6	128.7 / 3270	119.9 / 3045	40.9 / 1038	39.5 / 1003

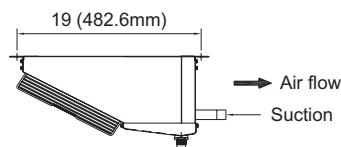
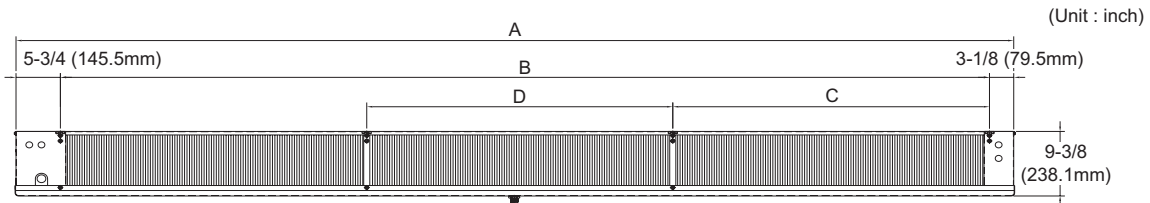

# CENTER MOUNT COOLERS

## MODEL NOMENCLATURE

<b>TCA</b>	<b>0 5 8</b>	<b>A</b>
<b>Model Series</b>	<b>Capacity</b>	<b>Voltage</b>
TCA= Air Defrost TCE= Electric Defrost	Size x 100= BTUH	A= 115/1/60 B= 208-230/1/60



## PERFORMANCE DATA & SPECIFICATIONS

### TCA Air Defrost Models 60Hz. With PSC Motors

Model	Capacity				Fan Data			PSC Motor Data					
	10°F/6°C TD 25°F/-4°C SST		15°F/8°C TD 25°F/-4°C SST					115V 1Ph 60Hz			208-230V 1Ph 60Hz		
	BTUH / Watts	BTUH / Watts	CFM	m³H	No.	HP	Total Amps	Total Watts	HP	Total Amps	Total Watts		
TCA058A*	5851	1713	8445	2473	755	1282	1	1/15	0.75	80	1/15	0.35	80
TCA087A*	8781	2572	12675	3712	1034	1757	1	1/15	0.75	80	1/15	0.35	80
TCA106A*	10695	3132	15773	4620	1920	3262	2	1/15	1.50	160	1/15	0.70	160
TCA140A*	14031	4109	19721	5776	2218	3768	2	1/15	1.50	160	1/15	0.70	160
TCA178A*	17805	5215	25024	7329	2162	3673	2	1/15	1.50	160	1/15	0.70	160
TCA197A*	19735	5780	28487	8343	2586	4394	3	1/15	2.25	240	1/15	1.05	240
TCA213A*	21388	6264	31542	9238	3840	6524	4	1/15	3.00	320	1/15	1.40	320
TCA284A*	28496	8346	42025	12308	3448	5859	4	1/15	3.00	320	1/15	1.40	320
TCA356A*	35613	10430	52522	15382	4310	7324	5	1/15	3.75	400	1/15	1.75	400

### TCE Electric Defrost Models 60Hz. With PSC Motors

Model	Capacity				Fan Data			PSC Motor Data 208-230V 1Ph 60Hz			Defrost Heater 208-230V 1Ph 60Hz	
	10°F/6°C TD 25°F/-4°C SST		15°F/8°C TD 25°F/-4°C SST					HP	Total Amps	Total Watts	Total Watts	Total Amps
	BTUH / Watts	BTUH / Watts	CFM	m³H	No.	HP	Total Amps	Total Watts	Total Watts	Total Amps		
TCE058B*	5851	1713	8445	2473	755	1282	1	1/15	0.35	80	2000	8.7
TCE087B*	8781	2572	12675	3712	1034	1757	1	1/15	0.35	80	2400	10.5
TCE106B*	10695	3132	15773	4620	1920	3262	2	1/15	0.70	160	2800	12.2
TCE140B*	14031	4109	19721	5776	2218	3768	2	1/15	0.70	160	4000	17.4
TCE178B*	17805	5215	25024	7329	2162	3673	2	1/15	0.70	160	4000	17.4
TCE197B*	19735	5780	28487	8343	2586	4394	3	1/15	1.05	240	4000	17.4
TCE213B*	21388	6264	31542	9238	3840	6524	4	1/15	1.40	320	5200	22.6
TCE284B*	28496	8346	42025	12308	3448	5859	4	1/15	1.40	320	5200	22.6
TCE356B*	35613	10430	52522	15382	4310	7324	5	1/15	1.75	400	7000	30.4

\* X: PSC motor TXV mounted \* M: PSC motor TXV, Solenoid mounted \* EX: EC motor, TXV mounted \* EM: EC motor, TXV, Solenoid mounted

# CENTER MOUNT COOLERS

## PHYSICAL DATA

Model		Connections (Inches)					Approx. Net Wt. (Lbs. / kg)
		No. of Fans	Coil Inlet	Suction	External Equalizer	Drain	
TCA058A	TCE058B	1	1/2 OD	7/8 OD	1/4 OD	3/4 MPT	66 / 30
TCA087A	TCE087B	1	1/2 OD	7/8 OD	1/4 OD	3/4 MPT	86 / 39
TCA106A	TCE106B	2	1/2 OD	7/8 OD	1/4 OD	3/4 MPT	108 / 49
TCA140A	TCE140B	2	1/2 OD	1-1/8 OD	1/4 OD	3/4 MPT	137 / 62
TCA178A	TCE178B	2	1/2 OD	1-1/8 OD	1/4 OD	3/4 MPT	141 / 64
TCA197A	TCE197B	3	1/2 OD	1-1/8 OD	1/4 OD	3/5 MPT	150 / 68
TCA213A	TCE213B	4	1/2 OD	1-1/8 OD	1/4 OD	3/6 MPT	187 / 85
TCA284A	TCE284B	4	1/2 OD	1-3/8 OD	1/4 OD	3/7 MPT	192 / 87
TCA356A	TCE356B	5	1/2 OD	1-3/8 OD	1/4 OD	3/8 MPT	231 / 105

### Dimensional Data For All Models

Model		Dimensions (Inches / mm)					
		A	B	C	D	E	F
TCA058A	TCE058B	57.3 / 1456.0	45.3 / 1150.4	- / -	- / -	6.7 / 171.3	7.9 / 201.3
TCA087A	TCE087B	79.3 / 2015.0	67.3 / 1709.4	- / -	- / -	6.7 / 171.3	7.9 / 201.3
TCA106A	TCE106B	79.3 / 2015.0	67.3 / 1709.4	33.6 / 854.7	- / -	9.2 / 234.8	10.4 / 264.8
TCA140A	TCE140B	79.3 / 2015.0	67.3 / 1709.4	33.6 / 854.7	- / -	13.0 / 330.0	14.2 / 360.0
TCA178A	TCE178B	79.3 / 2015.0	67.3 / 1709.4	33.6 / 854.7	- / -	13.0 / 330.0	14.2 / 360.0
TCA197A	TCE197B	79.3 / 2015.0	67.3 / 1709.4	22.7 / 575.6	22.0 / 558.4	13.0 / 330.0	14.2 / 360.0
TCA213A	TCE213B	101.3 / 2574.0	89.3 / 2268.4	22.7 / 575.6	22.0 / 558.4	13.0 / 330.0	14.2 / 360.0
TCA284A	TCE284B	101.3 / 2574.0	89.3 / 2268.4	22.7 / 575.6	22.0 / 558.4	13.0 / 330.0	14.2 / 360.0
TCA356A	TCE356B	123.3 / 3132.0	111.3 / 2826.4	22.7 / 575.6	22.0 / 558.4	13.0 / 330.0	14.2 / 360.0

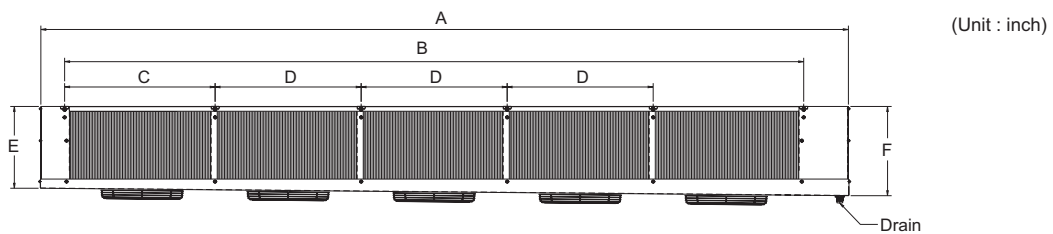

FRONT VIEW

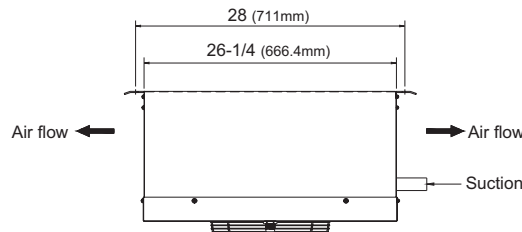

RIGHT SIDE VIEW

# CONDENSING UNITS

## CONDENSING UNIT STANDARD FEATURES

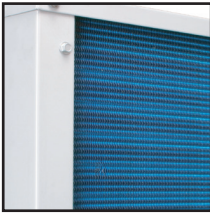

- Blue anti-corrosion fin increases the life span of the coil.
- Seamless inner groove copper tube is used to increase the heat exchange rate by reducing the space between the fin and the copper tube.



- Highest quality compressor in the world.



- 1 year compressor warranty (4 year extended warranty available).
- 1 year fan motor and parts warranty.



- Head pressure control stabilizes the freezing of liquid line, minimizes formation of flash gas to increase efficiency of the system, and prevents compressor damage by controlling high pressure.
- Experienced engineers have designed the system for maximum efficiency.
- Fan blades: Specifically matched with motors and coil for maximum air movement and cooling.



- Control box is designed for easy installation.
- Low pressure control is adjustable.
- All the parts are compliant with industry standards and interchangeable with readily available parts.
- Wiring: Easily accessible. Compressor comes with a wiring harness that is manufactured with connections that will not come loose with vibration.

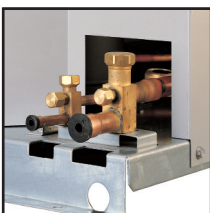

- Control box and service valves are located outside for easy service.
- Base: Heavy duty steel. Legs are 2-1/6" tall.
- Cabinet: Prepainted with galvanized body. Protects against corrosion.
- All products carry UL, cUL, ISO 9001 approvals.



**All Replacement Parts are Universal!**

# CONDENSING UNITS

## DIMENSIONAL DATA

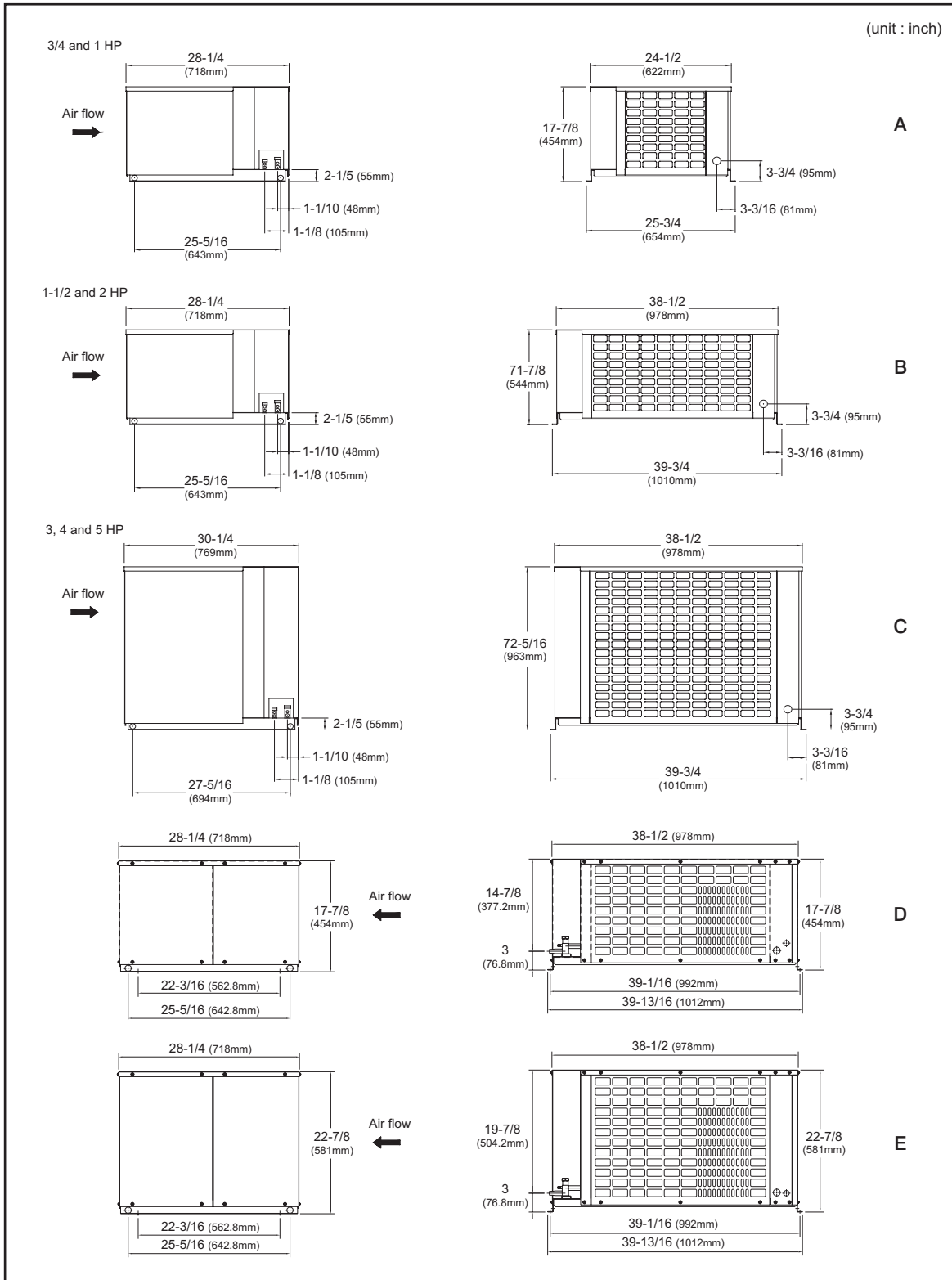

# CONDENSING UNITS

## DIMENSIONAL DATA

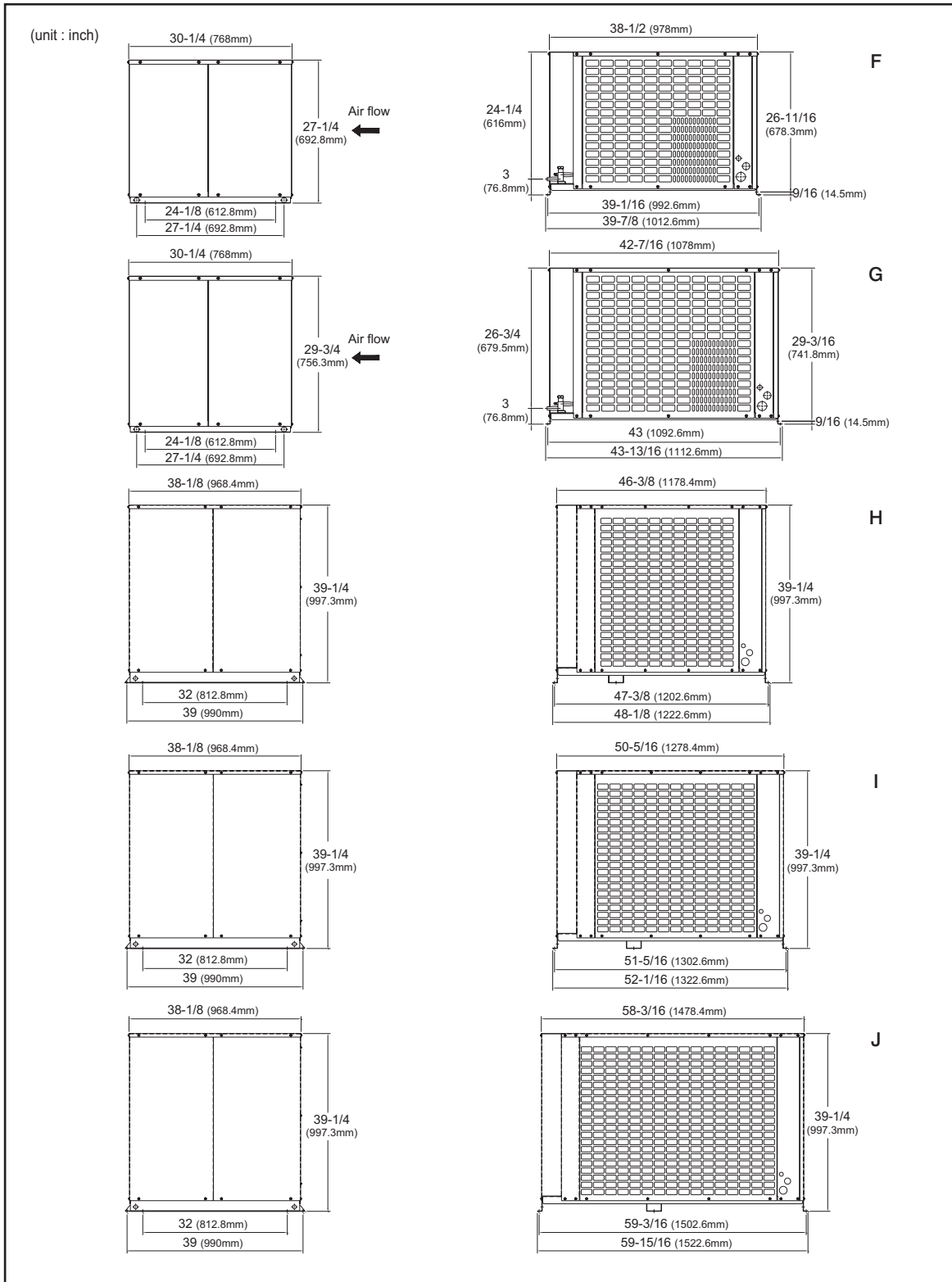



# CONDENSING UNITS

# R404A

## MODEL NOMENCLATURE

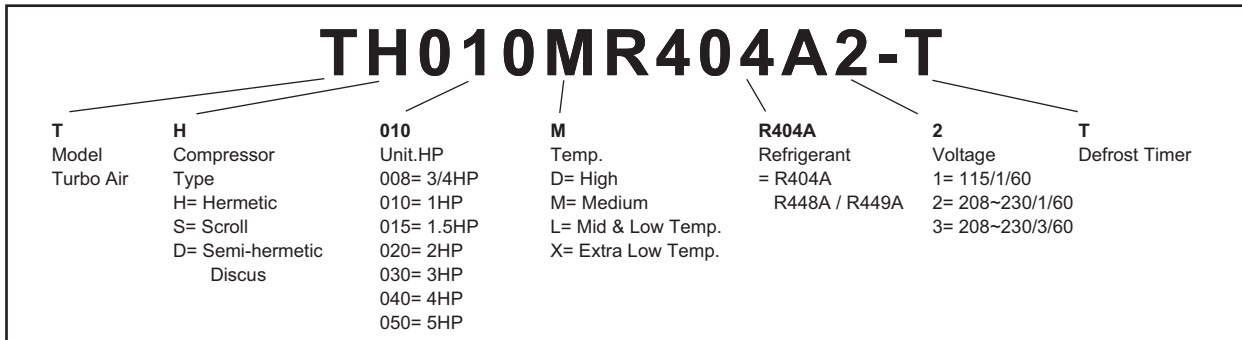

## UNIT SPEC. (EXTENDED MEDIUM TEMP.) : HERMETIC COMPRESSORS

Model	 Compressor	Connections (ID)		Receiver 90% Full Lbs	Fan(s) Data		Dimensions			Plan View	Net Weight (lbs.)	Sound dBA**
		Liquid	Suction		CFM	No.	W (in.)	D (in.)	H (in.)			
TH008MR404A2-T	MX21TG	3/8"	1/2"	6	980	1	28.27	24.49	17.87	A	141	-
TH010MR404A2-T	MS26TG	3/8"	5/8"	6	980	1	28.27	24.49	17.87	A	136	-
TH015LR404A2	CS10K6E-PFV	3/8"	5/8"	9	1840	2	38.50	28.27	17.87	B	210	69
TH015LR404A3	CS10K6E-TF5	3/8"	5/8"	9	1840	2	38.50	28.27	17.87	B	210	69
TH020LR404A2	CS12K6E-PFV	3/8"	7/8"	9	1600	2	38.50	28.27	17.87	B	213	71
TH020LR404A3	CS12K6E-TF5	3/8"	7/8"	9	1600	2	38.50	28.27	17.87	B	213	71
TH025LR404A2	CS14K6E-PFV	3/8"	7/8"	9	1600	2	38.50	28.27	17.87	B	214	72
TH025LR404A3	CS14K6E-TF5	3/8"	7/8"	9	1600	2	38.50	28.27	17.87	B	214	72
TH032LR404A2	CS20K6E-PFV	1/2"	7/8"	18	3970	1	38.50	30.28	27.28	C	274	73
TH032LR404A3	CS20K6E-TF5	1/2"	7/8"	18	3970	1	38.50	30.28	27.28	C	274	73
TH040LR404A2	CS27K6E-PFV	1/2"	1-1/8"	18	3760	1	38.50	30.28	27.28	C	285	71
TH040LR404A3	CS27K6E-TF5	1/2"	1-1/8"	18	3760	1	38.50	30.28	27.28	C	285	71
TH050LR404A2	CS33K6E-PFV	1/2"	1-1/8"	18	3760	1	38.50	30.28	27.28	C	292	71
TH050LR404A3	CS33K6E-TF5	1/2"	1-1/8"	18	3760	1	38.50	30.28	27.28	C	292	71

\*\* : Sound pressure are measured 10 feet from the product.

## UNIT SPEC. (EXTENDED MEDIUM TEMP.) : SCROLL COMPRESSORS

Model	 Compressor	Connections (ID)		Receiver 90% Full Lbs	Fan(s) Data		Dimensions			Plan View	Net Weight (lbs.)	Sound dBA**
		Liquid	Suction		CFM	No.	W (in.)	D (in.)	H (in.)			
TS015MR404A2-T	ZB11KQE-PFV	3/8"	5/8"	10	1840	2	38.50	28.27	17.87	A	204	69
TS020MR404A2-T	ZB15KQE-PFV	3/8"	7/8"	10	1600	2	38.50	28.27	17.87	A	208	69
TS020MR404A3-T	ZB15KQE-TF5	3/8"	7/8"	10	1600	2	38.50	28.27	22.87	B	218	69
TS025MR404A2-T	ZB19KQE-PFV	1/2"	7/8"	16	1890	2	38.50	30.28	27.28	C	286	71
TS025MR404A3-T	ZB19KQE-TF5	1/2"	7/8"	16	1890	2	38.50	30.28	27.28	C	317	71
TS030MR404A2-T	ZB21KQE-PFV	1/2"	7/8"	20	3970	1	38.50	30.28	27.28	C	317	70
TS030MR404A3-T	ZB21KQE-TF5	1/2"	7/8"	20	3970	1	42.44	30.28	29.78	D	343	70
TS040MR404A2-T	ZB29KQE-PFV	1/2"	1-1/8"	20	3760	1	58.20	38.10	39.20	F	813	71
TS040MR404A3-T	ZB29KQE-TF5	1/2"	1-1/8"	20	3760	1	58.20	38.10	39.20	F	908	71
TS050MR404A2-T	ZB38KQE-PFV	1/2"	1-1/8"	20	3760	1	42.44	30.28	29.78	D	343	72
TS050MR404A3-T	ZB38KQE-TF5	1/2"	1-1/8"	20	3760	1	58.20	38.10	39.20	F	813	72
TS060MR404A3-T	ZB45KQE-TF5	1/2"	1-1/8"	20	4030	1	58.20	38.10	39.20	F	908	73
TS075MR404A3-T	ZB66KQE-TF5	5/8"	1-3/8"	28	7730	2	58.20	38.10	39.20	F	813	77
TS100MR404A3-T	ZS92K4E-TWC	5/8"	1-3/8"	38	7730	2	58.20	38.10	39.20	F	908	79

\*\* : Sound pressure are measured 10 feet from the product.

# CONDENSING UNITS

# R404A

## UNIT SPEC. (LOW TEMP.) : HERMETIC COMPRESSORS

Model	Copeland Compressor	Connections (ID)		Receiver 90% Full Lbs	Fan(s) Data		Dimensions			Plan View	Net Weight (lbs.)	Sound dBA **
		Liquid	Suction		CFM	No.	W (in.)	D (in.)	H (in.)			
TH010LR404A2-T	CAJ2446Z†	3/8"	1/2"	6	980	1	28.27	24.49	17.87	A	148	68
TH015XR404A2	CF06K6E-PFV	3/8"	5/8"	6	950	1	24.49	28.27	17.87	A	170	71
TH015XR404A3	CF06K6E-TF5	3/8"	5/8"	6	950	1	24.49	28.27	17.87	A	170	71
TH020XR404A2	CF06K6E-PFV	3/8"	5/8"	9	1840	2	38.50	28.27	17.87	B	200	70
TH020XR404A3	CF06K6E-TF5	3/8"	5/8"	9	1840	2	38.50	28.27	17.87	B	200	70
TH025XR404A2	CF09K6E-PFV	3/8"	7/8"	9	1600	2	38.50	28.27	17.87	B	222	73
TH025XR404A3	CF09K6E-TF5	3/8"	7/8"	9	1600	2	38.50	28.27	17.87	B	222	73
TH030XR404A2	CF12K6E-PFV	1/2"	7/8"	14	1890	2	38.50	28.27	22.87	C	223	74
TH030XR404A3	CF12K6E-TF5	1/2"	7/8"	14	1890	2	38.50	28.27	22.87	C	223	74

† This model equipped with Tecumseh compressor.

\*\* : Sound pressure are measured 10 feet from the product.

## UNIT SPEC. (LOW TEMP.) : SCROLL COMPRESSORS

Model	Copeland Compressor	Connections (ID)		Receiver 90% Full Lbs	Fan(s) Data		Dimensions			Plan View	Net Weight (lbs.)	Sound dBA **
		Liquid	Suction		CFM	No.	W (in.)	D (in.)	H (in.)			
TS020XR404A2	ZF06K4E-PFV	1/2"	7/8"	13	2010	2	38.50	28.27	22.87	B	205	69
TS020XR404A3	ZF06K4E-TF5	1/2"	7/8"	13	2010	2	38.50	28.27	22.87	B	205	69
TS025XR404A2	ZF08K4E-PFV	1/2"	7/8"	13	2010	2	38.50	28.27	22.87	B	216	71
TS025XR404A3	ZF08K4E-TF5	1/2"	7/8"	13	2010	2	38.50	28.27	22.87	B	216	71
TS030XR404A2	ZF09K4E-PFV	1/2"	7/8"	13	2010	2	38.50	28.27	22.87	B	218	69
TS030XR404A3	ZF09K4E-TF5	1/2"	7/8"	13	2010	2	38.50	28.27	22.87	B	218	69
TS035XR404A2	ZF11K4E-PFV	1/2"	7/8"	13	2010	2	38.50	28.27	22.87	B	215	71
TS035XR404A3	ZF11K4E-TF5	1/2"	7/8"	13	2010	2	38.50	28.27	22.87	B	215	71
TS045XR404A2	ZF13K4E-PFV	1/2"	1-1/8"	18	3760	1	38.50	30.28	27.28	C	305	71
TS045XR404A3	ZF13K4E-TF5	1/2"	1-1/8"	18	3760	1	38.50	30.28	27.28	C	305	71
TS055XR404A2	ZF15K4E-PFV	1/2"	1-1/8"	18	3760	1	38.50	30.28	27.28	C	312	72
TS055XR404A3	ZF15K4E-TF5	1/2"	1-1/8"	18	3760	1	38.50	30.28	27.28	C	312	72
TS060XR404A3	ZF18K4E-TF5	1/2"	1-1/8"	18	3760	1	38.50	30.28	27.28	C	315	73
TS075XR404A3	ZF24K4E-TWC	1/2"	1-1/8"	28	4250	1	46.40	38.10	39.20	E	650	79
TS100XR404A3	ZF33K4E-TWC	1/2"	1-1/8"	28	4250	1	46.40	38.10	39.20	E	650	79

\*\* : Sound pressure are measured 10 feet from the product.

## UNIT SPEC. (LOW TEMP.) : SEMI-HERMETIC DISCUS COMPRESSORS

Model	Copeland Compressor	Connections (ID)		Receiver 90% Full Lbs	Fan(s) Data		Dimensions			Plan View	Net Weight (lbs.)	Sound dBA **
		Liquid	Suction		CFM	No.	W (in.)	D (in.)	H (in.)			
TD040XR404A3	2DL3F20KE-TFC	1/2"	1-1/8"	20	4350	1	38.1	46.4	39.2	H	634	78
TD060XR404A3	3DA3F28KE-TFC	1/2"	1-1/8"	28	4280	1	38.1	46.4	39.2	H	721	81
TD075XR404A3	3DB3F33KE-TFC	1/2"	1-1/8"	28	4310	1	38.1	50.3	39.2	I	736	81
TD100XR404A3	3DS3F46KE-TFC	5/8"	1-3/8"	38	7730	2	38.1	58.2	39.2	J	852	82

\*\* : Sound pressure are measured 10 feet from the product.

# CONDENSING UNITS

# R404A

## ELECTRICAL DATA (EXTENDED MEDIUM TEMP.) : HERMETIC COMPRESSORS

Model	 Copeland Compressor	Power Supply			Compressor		Fan Motor	MCA	MOPD
		Volts	Ph	Hz	RLA	LRA	FLA		
TH008MR404A-T	MX21TG	208-230	1	60	8.3	38	0.47	15.0	15
TH010MR404A-T	MS26TG	208-230	1	60	8.3	43	0.47	15.0	15
TH015LR404A2	CS10K6E-PFV	208-230	1	60	10.9	56	0.94	15.0	20
TH020LR404A2	CS12K6E-PFV	208-230	1	60	10.9	56	0.94	15.0	20
TH025LR404A2	CS14K6E-PFV	208-230	1	60	12.4	61	0.94	16.4	20
TH032LR404A2	CS20K6E-PFV	208-230	1	60	18.6	96	2.20	25.5	40
TH040LR404A2	CS27K6E-PFV	208-230	1	60	23.9	121	2.20	32.1	50
TH050LR404A2	CS33K6E-PFV	208-230	1	60	30.7	125	2.20	40.6	60
TH015LR404A3	CS10K6E-TF5	208-230	3	60	7.5	51	0.94	15.0	15
TH020LR404A3	CS12K6E-TF5	208-230	3	60	7.5	51	0.94	15.0	15
TH025LR404A3	CS14K6E-TF5	208-230	3	60	9.1	55	0.94	15.0	20
TH032LR404A3	CS20K6E-TF5	208-230	3	60	11.4	75	2.20	16.5	20
TH040LR404A3	CS27K6E-TF5	208-230	3	60	15.6	105	2.20	21.7	30
TH050LR404A3	CS33K6E-TF5	208-230	3	60	18.7	102	2.20	25.6	40

## ELECTRICAL DATA (EXTENDED MEDIUM TEMP.) : SCROLL COMPRESSORS

Model	 Copeland Compressor	Power Supply			Compressor		Fan Motor	MCA	MOPD
		Volts	Ph	Hz	RLA	LRA	FLA		
TS015MR404A2-T	ZB11KCE-PFV	208 - 230	1	60	10	45	0.94	15.0	20
TS020MR404A2-T	ZB15KQE-PFV	208 - 230	1	60	15.7	61	0.94	20.6	30
TS025MR404A2-T	ZB19KQE-PFV	208 - 230	1	60	17.9	72.5	0.94	23.3	40
TS030MR404A2-T	ZB21KQE-PFV	208 - 230	1	60	20.7	95	2.20	28.1	45
TS040MR404A2-T	ZB29KQE-PFV	208 - 230	1	60	25	137	2.20	33.5	50
TS050MR404A2-T	ZB38KQE-PFV	208 - 230	1	60	31.1	144	2.20	41.1	70
TS020MR404A3-T	ZB15KQE-TF5	208 - 230	3	60	8.9	55	0.94	15.0	20
TS025MR404A3-T	ZB19KQE-TF5	208 - 230	3	60	10	63	0.94	15.0	20
TS030MR404A3-T	ZB21KQE-TF5	208 - 230	3	60	12.1	77	2.20	17.3	25
TS040MR404A3-T	ZB29KQE-TF5	208 - 230	3	60	17.1	91	2.20	23.6	40
TS050MR404A3-T	ZB38KQE-TF5	208 - 230	3	60	22.1	128	2.20	29.8	50
TS060MR404A3-T	ZB45KQE-TF5	208 - 230	3	60	23.1	156	2.20	31.1	50
TS075MR404A3-T	ZB66KCE-TF5	208 - 230	3	60	26.9	225	4.40	38.0	60
TS100MR404A3-T	ZS92K4E-TWC	208 - 230	3	60	47.4	350	4.40	63.7	100

## ELECTRICAL DATA (LOW TEMP.) : HERMETIC COMPRESSORS

Model	 Copeland Compressor	Power Supply			Compressor		Fan Motor	MCA	MOPD
		Volts	Ph	Hz	RLA	LRA	FLA		
TH010LR404A2-T	CAJ2446Z†	208 - 230	1	60	4.8	37	0.47	15.0	15
TH015XR404A2	CF06K6E-PFV	208 - 230	1	60	11.4	59.2	0.47	15.0	25
TH020XR404A2	CF06K6E-PFV	208 - 230	1	60	11.4	59.2	0.94	15.0	25
TH025XR404A2	CF09K6E-PFV	208 - 230	1	60	16.7	87	0.94	21.8	30
TH030XR404A2	CF12K6E-PFV	208 - 230	1	60	20.5	105	0.94	26.5	40
TH015XR404A3	CF06K6E-TF5	208 - 230	3	60	7	52	0.47	15.0	15
TH020XR404A3	CF06K6E-TF5	208 - 230	3	60	7	52	0.94	15.0	15
TH025XR404A3	CF09K6E-TF5	208 - 230	3	60	10.2	72.2	0.94	15.0	20
TH030XR404A3	CF12K6E-TF5	208 - 230	3	60	12.3	85	0.94	16.3	25

† This model equipped with Tecumseh compressor.

- MCA Minimum Circuit Ampacity does not include evaporators electrical requirements (Evaporator fan motor amps, defrost heater amps).

# CONDENSING UNITS

# R404A

## ELECTRICAL DATA (LOW TEMP.) : SCROLL COMPRESSORS

Model	Copeland® Compressor	Power Supply			Compressor		Fan Motor	MCA	MOPD
		Volts	Ph	Hz	RLA	LRA	FLA		
TS020XR404A2	ZF06K4E-PFV	208 - 230	1	60	13.6	61	0.94	17.9	30
TS025XR404A2	ZF08K4E-PFV	208 - 230	1	60	16.4	73	0.94	21.4	30
TS030XR404A2	ZF09K4E-PFV	208 - 230	1	60	14.3	88	0.94	18.8	30
TS035XR404A2	ZF11K4E-PFV	208 - 230	1	60	20.7	109	0.94	26.8	45
TS045XR404A2	ZF13K4E-PFV	208 - 230	1	60	26.8	129	2.20	35.7	60
TS055XR404A2	ZF15K4E-PFV	208 - 230	1	60	27.5	169	2.20	36.6	60
TS020XR404A3	ZF06K4E-TF5	208 - 230	3	60	8.3	55	0.94	11.3	15
TS025XR404A3	ZF08K4E-TF5	208 - 230	3	60	9.6	63	0.94	12.9	20
TS030XR404A3	ZF09K4E-TF5	208 - 230	3	60	9.6	77	0.94	12.9	20
TS035XR404A3	ZF11K4E-TF5	208 - 230	3	60	13.6	88	0.94	17.9	30
TS045XR404A3	ZF13K4E-TF5	208 - 230	3	60	15.0	99	2.20	21.0	30
TS055XR404A3	ZF15K4E-TF5	208 - 230	3	60	18.9	123	2.20	25.8	45
TS060XR404A3	ZF18K4E-TF5	208 - 230	3	60	23.9	156	2.20	32.1	50
TS075XR404A3	ZF24K4E-TWC	208 - 230	3	60	26.1	189	2.20	34.8	60
TS100XR404A3	ZF33K4E-TWC	208 - 230	3	60	35.0	278	2.20	46.0	80

## ELECTRICAL DATA (LOW TEMP.) : SEMI-HERMETIC COMPRESSORS

Model	Copeland® Compressor	Power Supply			Compressor		Fan Motor	MCA	MOPD
		Volts	Ph	Hz	RLA	LRA	FLA		
TD040XR404A3	2DL3F20KE-TFC	208-230	3	60	23.6	161	2.20	31.7	50
TD060XR404A3	3DA3F28KE-TFC	208-230	3	60	24.0	150	2.20	32.2	50
TD075XR404A3	3DB3F33KE-TFC	208-230	3	60	27.6	161	2.20	36.7	60
TD100XR404A3	3DS3F46KE-TFC	208-230	3	60	37.2	215	4.40	50.9	80

- MCA = Minimum Circuit Ampacity does not include evaporators electrical requirements (Evaporator fan motor amps, defrost heater amps).  
 - MOPD = Maximum ratings of protection device.

## PERFORMANCE (EXTENDED MEDIUM TEMP.) : HERMETIC COMPRESSORS

R-404A Model	Copeland® Compressor	Capacity BTU/HR @ 90°F. Ambient Suction Temperature °F.						
		30°F	25°F	20°F	15°F	10°F	0°F	-10°F
TH008MR404A*	MX21TG	9947	9099	8327	7541	6819	5462	4256
TH010MR404A*	MS26TG	11972	11167	10185	9410	8471	6877	5258
R-404A Model	Copeland® Compressor	Capacity BTU/HR @ 95°F. Ambient Suction Temperature °F.						
		30°F	25°F	20°F	15°F	10°F	0°F	-10°F
TH008MR404A*	MX21TG	9401	8591	7856	7109	6426	5147	4019
TH010MR404A*	MS26TG	11422	10390	9699	8730	8051	6345	4825
R-404A Model	Copeland® Compressor	Capacity BTU/HR @ 100°F. Ambient Suction Temperature °F.						
		30°F	25°F	20°F	15°F	10°F	0°F	-10°F
TH008MR404A*	MX21TG	8857	8086	7388	6678	6034	4834	3783
TH010MR404A*	MS26TG	10871	9873	8970	8277	7420	5991	4536
R-404A Model	Copeland® Compressor	Capacity BTU/HR @ 110°F. Ambient Suction Temperature °F.						
		30°F	25°F	20°F	15°F	10°F	0°F	-10°F
TH008MR404A*	MX21TG	8128	7578	6919	6249	5643	4415	3389
TH010MR404A*	MS26TG	-	9096	8241	7371	6581	5282	3960

\* : -T installed defrost timer.

# CONDENSING UNITS

# R404A

## PERFORMANCE (EXTENDED MEDIUM TEMP.) : HERMETIC COMPRESSORS

R-404A Model	Copeland Compressor	Capacity BTU/HR @ 90°F. Ambient Suction Temperature °F.						
		30°F	25°F	20°F	0°F	-10°F	-20°F	-25°F
TH015LR404A	CS10K6E	15940	14660	13330	7700	4900	3610	2330
TH020LR404A	CS12K6E	18050	16680	15150	8940	6170	4410	2640
TH025LR404A	CS14K6E	19830	18220	16770	10810	7840	6360	4470
TH032LR404A	CS20K6E	34200	31310	28580	16910	11960	9440	6930
TH040LR404A	CS27K6E	43970	39510	35150	20560	14980	11830	8690
TH050LR404A	CS33K6E	49470	45010	40420	24860	18110	14300	10500

R-404A Model	Copeland Compressor	Capacity BTU/HR @ 95°F. Ambient Suction Temperature °F.						
		30°F	25°F	20°F	0°F	-10°F	-20°F	-25°F
TH015LR404A	CS10K6E	15040	13830	12580	7260	4620	3410	2200
TH020LR404A	CS12K6E	17030	15740	14290	8430	5820	4160	2490
TH025LR404A	CS14K6E	18710	17190	15820	10200	7400	6000	4220
TH032LR404A	CS20K6E	32260	29540	26960	15950	11280	8910	6540
TH040LR404A	CS27K6E	41480	37270	33160	19400	14130	11160	8200
TH050LR404A	CS33K6E	46670	42460	38130	23450	17080	13490	9900

R-404A Model	Copeland Compressor	Capacity BTU/HR @ 100°F. Ambient Suction Temperature °F.						
		30°F	25°F	20°F	0°F	-10°F	-20°F	-25°F
TH015LR404A	CS10K6E	14140	13000	11830	6820	4340	3210	2070
TH020LR404A	CS12K6E	16010	14800	13430	7920	5470	3910	2340
TH025LR404A	CS14K6E	17590	16160	14870	9590	6960	5640	3970
TH032LR404A	CS20K6E	30320	27770	25340	14990	10600	8380	6150
TH040LR404A	CS27K6E	38980	35030	31180	18240	13290	10500	7700
TH050LR404A	CS33K6E	43860	39910	35840	22050	16050	12690	9310

R-404A Model	Copeland Compressor	Capacity BTU/HR @ 110°F. Ambient Suction Temperature °F.						
		30°F	25°F	20°F	0°F	-10°F	-20°F	-25°F
TH015LR404A	CS10K6E	12780	11700	7110	5690	3220	2540	1870
TH020LR404A	CS12K6E	14870	13540	12180	6820	4400	3480	2550
TH025LR404A	CS14K6E	16280	15050	13780	8600	6170	4870	3580
TH032LR404A	CS20K6E	26350	24040	21690	12250	8020	6340	4650
TH040LR404A	CS27K6E	36150	31240	27520	15210	11290	8920	6550
TH050LR404A	CS33K6E	39870	35920	32070	18230	12840	10150	7450

## PERFORMANCE (EXTENDED MEDIUM TEMP.) : SCROLL COMPRESSORS

R-404A Model	Copeland Compressor	Capacity BTU/HR @ 90°F. Ambient Suction Temperature °F.							
		40°F	30°F	25°F	20°F	15°F	10°F	0°F	-10°F
TS015MR404A-T	ZB11KCE	18240	15080	13825	12650	11540	10415	8354	6506
TS020MR404A-T	ZB15KQE	24540	20380	18760	17250	15790	14310	11600	9317
TS025MR404A-T	ZB19KQE	30660	25460	23430	21550	19720	17850	14540	11600
TS030MR404A-T	ZB21KQE	36660	30460	28015	25750	23580	21360	17380	13880
TS040MR404A-T	ZB29KQE	48900	40560	37235	34150	31080	28120	22580	17720
TS050MR404A-T	ZB38KQE	61600	51000	46850	43000	39170	35280	28140	22080
TS060MR404A-T	ZB45KQE	72300	60100	55285	50800	46420	42190	34280	27460
TS075MR404A-T	ZB66KCE	103000	88300	81200	73950	68375	62000	50240	40540
TS100MR404A-T	ZS92K4E	133500	116300	108000	99300	91350	84000	69650	56750

# CONDENSING UNITS

# R404A

## PERFORMANCE (EXTENDED MEDIUM TEMP.) : SCROLL COMPRESSORS

R-404A Model	Copeland Compressor	Capacity BTU/HR @ 95°F. Ambient Suction Temperature °F.							
		40°F	30°F	25°F	20°F	15°F	10°F	0°F	-10°F
TS015MR404A-T	ZB11KCE	17390	14350	13180	12100	11027.5	9940	7939	6284
TS020MR404A-T	ZB15KQE	23410	19430	17900	16500	15090	13660	11100	9068
TS025MR404A-T	ZB19KQE	29260	24280	22360	20600	18870	17100	13890	11300
TS030MR404A-T	ZB21KQE	34980	29060	26730	24600	22555	20460	16580	13520
TS040MR404A-T	ZB29KQE	46620	38630	35480	32600	29680	26820	21530	17180
TS050MR404A-T	ZB38KQE	58700	48530	44580	41000	37320	33580	26740	21420
TS060MR404A-T	ZB45KQE	69050	57350	52780	48600	44320	40340	32730	26740
TS075MR404A-T	ZB66KCE	98000	83250	77425	70600	64850	59000	48140	38740
TS100MR404A-T	ZS92K4E	127500	111700	103000	94800	87225	80250	66800	54500

R-404A Model	Copeland Compressor	Capacity BTU/HR @ 100°F. Ambient Suction Temperature °F.							
		40°F	30°F	25°F	20°F	15°F	10°F	0°F	-10°F
TS015MR404A-T	ZB11KCE	16540	13600	12505	11500	10475	9435	7506	5914
TS020MR404A-T	ZB15KQE	22260	18480	17025	15700	14370	13010	10584	8653
TS025MR404A-T	ZB19KQE	27860	23080	21260	19600	17960	16290	13220	10800
TS030MR404A-T	ZB21KQE	33280	27660	25430	23400	21470	19500	15780	12920
TS040MR404A-T	ZB29KQE	44320	36680	33680	30950	28200	25490	20440	16280
TS050MR404A-T	ZB38KQE	55700	46080	42280	38850	35390	31850	25340	20320
TS060MR404A-T	ZB45KQE	65800	54600	50230	46250	42180	38430	31160	25540
TS075MR404A-T	ZB66KCE	93950	79850	74325	67800	62250	56600	45920	36910
TS100MR404A-T	ZS92K4E	121500	105200	98400	90000	82950	76500	63800	52200

R-404A Model	Copeland Compressor	Capacity BTU/HR @ 110°F. Ambient Suction Temperature °F.							
		40°F	30°F	25°F	20°F	15°F	10°F	0°F	-10°F
TS015MR404A-T	ZB11KCE	14680	12100	11092	10210	9290	8349	6562	5075
TS020MR404A-T	ZB15KQE	19960	16500	15205	14050	12880	11680	9486	7760
TS025MR404A-T	ZB19KQE	24900	20600	18990	17550	16090	14590	11820	9692
TS030MR404A-T	ZB21KQE	29800	24700	22725	20950	19230	17470	14160	11630
TS040MR404A-T	ZB29KQE	39480	32620	29975	27600	25120	22730	18120	14390
TS050MR404A-T	ZB38KQE	49700	40940	37540	34500	31450	28320	22540	18120
TS060MR404A-T	ZB45KQE	58900	48700	44850	41400	37800	34470	27920	22870
TS075MR404A-T	ZB66KCE	84500	72200	66575	60800	55800	50680	41200	32880
TS100MR404A-T	ZS92K4E	109500	95000	88050	80900	74800	69300	58100	47940

## PERFORMANCE (LOW TEMP.) : HERMETIC COMPRESSORS

R-404A Model	Copeland Compressor	Capacity BTU/HR @ 90°F. Ambient Suction Temperature °F.						
		30°F	25°F	20°F	0°F	-10°F	-20°F	-25°F
TH010LR404A	CAJ2446Z†	-	8591	8018	5750	4686	3699	3244

R-404A Model	Copeland Compressor	Capacity BTU/HR @ 95°F. Ambient Suction Temperature °F.						
		30°F	25°F	20°F	0°F	-10°F	-20°F	-25°F
TH010LR404A	CAJ2446Z†	-	8278	7717	5497	4461	3503	3061

R-404A Model	Copeland Compressor	Capacity BTU/HR @100°F. Ambient Suction Temperature °F.						
		30°F	25°F	20°F	0°F	-10°F	-20°F	-25°F
TH010LR404A	CAJ2446Z†	-	7965	7416	5245	4237	3307	2878

R-404A Model	Copeland Compressor	Capacity BTU/HR @ 110°F. Ambient Suction Temperature °F.						
		30°F	25°F	20°F	0°F	-10°F	-20°F	-25°F
TH010LR404A	CAJ2446Z†	-	7339	6814	4741	3788	2915	2513

† This model equipped with Tecumseh compressor.

# CONDENSING UNITS

# R404A

## PERFORMANCE (LOW TEMP.) : HERMETIC COMPRESSORS

R-404A Model	Copeland Compressor	Capacity BTU/HR @ 90°F. Ambient Suction Temperature °F.						
		0°F	-5°F	-10°F	-15°F	-20°F	-25°F	-30°F
TH015XR404A	CF06K6E	10664	9460	8300	7174	6098	5008	4101
TH020XR404A	CF06K6E	11960	10468	9110	7779	6644	5494	4450
TH025XR404A	CF09K6E	16820	14750	13030	11070	9460	7804	6318
TH030XR404A	CF12K6E	20080	18050	15820	13960	11960	10142	8418

R-404A Model	Copeland Compressor	Capacity BTU/HR @ 95°F. Ambient Suction Temperature °F.						
		0°F	-5°F	-10°F	-15°F	-20°F	-25°F	-30°F
TH015XR404A	CF06K6E	9992	9013	7896	6811	5666	4726	3706
TH020XR404A	CF06K6E	11000	9604	8435	7295	6098	5008	4101
TH025XR404A	CF09K6E	15660	13910	12080	10245	8584	7174	5884
TH030XR404A	CF12K6E	18350	16520	14680	12910	11060	9352	7698

R-404A Model	Copeland Compressor	Capacity BTU/HR @ 100°F. Ambient Suction Temperature °F.						
		0°F	-5°F	-10°F	-15°F	-20°F	-25°F	-30°F
TH015XR404A	CF06K6E	9320	8268	7226	6218	5248	4265	3469
TH020XR404A	CF06K6E	10328	9013	7896	6690	5666	4632	3706
TH025XR404A	CF09K6E	14700	12860	11320	9587	8146	6554	5369
TH030XR404A	CF12K6E	17480	15740	13800	12100	10344	8720	7126

R-404A Model	Copeland Compressor	Capacity BTU/HR @ 110°F. Ambient Suction Temperature °F.						
		0°F	-5°F	-10°F	-15°F	-20°F	-25°F	-30°F
TH015XR404A	CF06K6E	7976	7070	6162	5171	4346	3585	2846
TH020XR404A	CF06K6E	8816	7820	6690	5628	4642	3840	3050
TH025XR404A	CF09K6E	12580	10979	9616	8120	6880	5611	4484
TH030XR404A	CF12K6E	14870	13450	11820	10326	8755	7334	5902

## PERFORMANCE (LOW TEMP.) : SCROLL COMPRESSORS

R-404A Model	Copeland Compressor	Capacity BTU/HR @ 90°F. Ambient Suction Temperature °F.							
		0°F	-10°F	-15°F	-20°F	-25°F	-30°F	-35°F	-40°F
TS020XR404A	ZF06K4E	12110	9886	8936	8042	7193	6403	5655	4904
TS025XR404A	ZF08K4E	15071	12331	11143	9941	8981	7950	7123	6240
TS030XR404A	ZF09K4E	16371	13667	12444	11301	10071	9002	7925	7038
TS035XR404A	ZF11K4E	20013	16443	15036	13650	12243	10830	9685	8547
TS045XR404A	ZF13K4E	26096	21347	19208	17248	15355	13440	11827	10391
TS055XR404A	ZF15K4E	31053	25811	23064	20870	18595	16688	14715	12949
TS060XR404A	ZF18K4E	36450	30215	27076	24405	21909	19587	17331	15347
TS075XR404A	ZF24K4E	41756	34330	30950	27768	24835	22069	19573	17139
TS100XR404A	ZF33K4E	56322	46894	42746	38524	34744	30866	27475	23922

R-404A Model	Copeland Compressor	Capacity BTU/HR @ 95°F. Ambient Suction Temperature °F.							
		0°F	-10°F	-15°F	-20°F	-25°F	-30°F	-35°F	-40°F
TS020XR404A	ZF06K4E	11544	9539	8626	7769	6958	6190	5464	4728
TS025XR404A	ZF08K4E	14433	11809	10687	9537	8622	7633	6841	5986
TS030XR404A	ZF09K4E	15796	13066	11950	10763	9597	8652	7617	6769
TS035XR404A	ZF11K4E	19068	15855	14364	12957	11760	10397	9323	8232
TS045XR404A	ZF13K4E	24976	20395	18368	16464	14694	12925	11393	10026
TS055XR404A	ZF15K4E	29805	24685	22083	20034	17832	16045	14141	12455
TS060XR404A	ZF18K4E	35040	28908	26160	23586	21188	18965	16808	14892
TS075XR404A	ZF24K4E	39853	32885	29682	26728	23899	21237	18845	16515
TS100XR404A	ZF33K4E	53352	44626	40802	36742	33199	29808	26320	23101

# CONDENSING UNITS

# R404A

## PERFORMANCE (LOW TEMP.) : SCROLL COMPRESSORS

R-404A Model	Copeland Compressor	Capacity BTU/HR @ 100°F. Ambient Suction Temperature °F.							
		0°F	-10°F	-15°F	-20°F	-25°F	-30°F	-35°F	-40°F
TS020XR404A	ZF06K4E	11075	9097	8234	7422	6655	5917	5177	4508
TS025XR404A	ZF08K4E	13749	11336	10371	9258	8375	7415	6533	5759
TS030XR404A	ZF09K4E	15144	12699	11441	10404	9280	8372	7371	6501
TS035XR404A	ZF11K4E	18318	15336	14015	12631	11396	10171	9055	8008
TS045XR404A	ZF13K4E	24013	19443	17528	15680	14022	12421	10967	9668
TS055XR404A	ZF15K4E	28807	23784	21299	19199	17069	15391	13560	11946
TS060XR404A	ZF18K4E	33880	27984	25146	22726	20460	18326	16280	14410
TS075XR404A	ZF24K4E	38111	31528	28466	25655	22990	20472	18162	15947
TS100XR404A	ZF33K4E	51920	43538	39490	35585	32219	28985	25542	22440

R-404A Model	Copeland Compressor	Capacity BTU/HR @ 110°F. Ambient Suction Temperature °F.							
		0°F	-10°F	-15°F	-20°F	-25°F	-30°F	-35°F	-40°F
TS020XR404A	ZF06K4E	10109	8426	7584	6849	6108	5439	4793	4160
TS025XR404A	ZF08K4E	12270	10390	9506	8493	7556	6765	5951	5295
TS030XR404A	ZF09K4E	13999	11427	10306	9436	8419	7628	6719	5863
TS035XR404A	ZF11K4E	16764	13952	12840	11619	10488	9401	8393	7439
TS045XR404A	ZF13K4E	21611	17573	15896	14288	12836	11363	10143	9023
TS055XR404A	ZF15K4E	26318	21667	19403	17738	15762	14297	12610	11087
TS060XR404A	ZF18K4E	30800	25344	22836	20713	18766	16786	15070	13299
TS075XR404A	ZF24K4E	34874	29023	26288	23744	21348	18900	16706	14670
TS100XR404A	ZF33K4E	46368	39402	35728	32312	29355	26477	23363	20563

## PERFORMANCE (LOW TEMP.) : SEMI-HERMETIC COMPRESSORS

R-404A Model	Copeland Compressor	Capacity BTU/HR @ 90°F. Ambient Suction Temperature °F.						
		0°F	-10°F	-20°F	-25°F	-30°F	-35°F	-40°F
TD040XR404A	2DL3F20KE	38320	31200	24500	21550	18590	16210	13820
TD060XR404A	3DA3F28KE	49300	40810	32530	28820	25110	22130	19140
TD075XR404A	3DB3F33KE	57490	47800	38230	33890	29550	26050	22550
TD100XR404A	3DS3F46KE	82110	67850	54240	48140	42040	37020	31990

R-404A Model	Copeland Compressor	Capacity BTU/HR @ 95°F. Ambient Suction Temperature °F.						
		0°F	-10°F	-20°F	-25°F	-30°F	-35°F	-40°F
TD040XR404A	ZF06K4E	36470	29620	23140	20270	17400	15080	12750
TD060XR404A	ZF11K4E	47060	38920	30940	27330	23710	20770	17830
TD075XR404A	ZF13K4E	54880	45630	36410	32190	27960	24500	21030
TD100XR404A	ZF18K4E	78620	64870	51680	45730	39780	34850	29910

R-404A Model	Copeland Compressor	Capacity BTU/HR @ 100°F. Ambient Suction Temperature °F.						
		0°F	-10°F	-20°F	-25°F	-30°F	-35°F	-40°F
TD040XR404A	ZF06K4E	34630	28040	21790	19010	16220	13960	11690
TD060XR404A	ZF11K4E	44820	37050	29370	25850	22330	19430	16530
TD075XR404A	ZF13K4E	52280	43470	34600	30490	26380	22950	19520
TD100XR404A	ZF18K4E	75150	61900	49130	43340	37540	32690	27840

R-404A Model	Copeland Compressor	Capacity BTU/HR @ 110°F. Ambient Suction Temperature °F.						
		0°F	-10°F	-20°F	-25°F	-30°F	-35°F	-40°F
TD040XR404A	ZF06K4E	30970	24900	19100	16500	13890	11740	9590
TD060XR404A	ZF11K4E	40390	33350	26250	22930	19610	16790	13960
TD075XR404A	ZF13K4E	47130	39210	31040	27150	23260	19900	16540
TD100XR404A	ZF18K4E	68260	56030	44090	38600	33100	28420	23740



# CONDENSING UNITS

# R448A/449A

## MODEL NOMENCLATURE

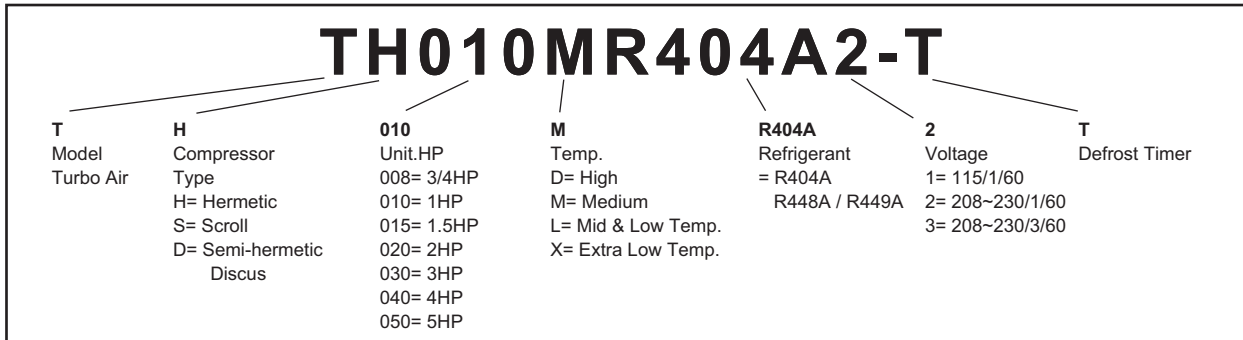

## Unit Spec - Medium Temp. Models - Scroll Compressors

Model Number	Fig. *	Compressor	Connections (ID)		Receiver 90% Full (lbs.)	Fan(s) Data		Dimensions			Net Weight (lbs.)	Sound dBA**
			Liquid	Suction		CFM	No.	D (in.)	W (in.)	H (in.)		
TS015MR404A-T	A	ZS11KAE	3/8"	5/8"	10	1840	2	38.5	28.27	17.87	204	69
TS020MR404A-T	A	ZB15KQE	3/8"	7/8"	10	1600	2	38.5	28.27	17.87	208	69
TS025MR404A-T	B	ZB19KQE	1/2"	7/8"	16	1890	2	38.5	28.27	22.87	218	71
TS030MR404A-T	C	ZB21KQE	1/2"	7/8"	20	3970	1	38.5	30.28	27.28	286	70
TS040MR404A-T	C	ZB29KQE	1/2"	1-1/8"	20	3760	1	38.5	30.28	27.28	317	71
TS050MR404A-T	C	ZB38KQE	1/2"	1-1/8"	20	3760	1	38.5	30.28	27.28	317	72
TS060MR404A-T	D	ZB45KQE	1/2"	1-1/8"	20	4030	1	42.44	30.28	29.73	343	73
TS075MR404A-T	F	ZB66KCE	5/8"	1-3/8"	28	7730	2	58.2	38.1	39.2	813	77
TS100MR404A-T	F	ZB95KCE	5/8"	1-3/8"	28	7730	2	58.2	38.1	39.2	908	79

\*\* : Sound pressure are measured 10 feet from the product.

## Unit Spec - Extra Low Temp. Models - Scroll Compressors

Model Number	Fig. *	Compressor	Connections (ID)		Receiver 90% Full (lbs.)	Fan(s) Data		Dimensions			Net Weight (lbs.)	Sound dBA**
			Liquid	Suction		CFM	No.	D (in.)	W (in.)	H (in.)		
TS020XR404A	B	ZF06K4E	1/2"	7/8"	13	2010	2	38.5	28.27	22.87	205	69
TS025XR404A	B	ZF08K4E	1/2"	7/8"	13	2010	2	38.5	28.27	22.87	216	71
TS030XR404A	B	ZF09K4E	1/2"	7/8"	13	2010	2	38.5	28.27	22.87	218	69
TS035XR404A	B	ZF11K4E	1/2"	7/8"	13	2010	2	38.5	28.27	22.87	215	71
TS045XR404A	C	ZF13K4E	1/2"	1-1/8"	18	3760	1	38.5	30.28	27.28	305	71
TS055XR404A	C	ZF15K4E	1/2"	1-1/8"	18	3760	1	38.5	30.28	27.28	312	72
TS060XR404A	C	ZF18K4E	1/2"	1-1/8"	18	3760	1	38.5	30.28	27.28	315	73
TS075XR404A	E	ZF25K4E	1/2"	1-1/8"	28	4250	1	46.4	38.1	39.2	650	79
TS100XR404A	E	ZF34K5E	1/2"	1-1/8"	28	4250	1	46.4	38.1	39.2	650	79

\*\* : Sound pressure are measured 10 feet from the product.

## Unit spec - Semi-hermetic Compressor

Model Number	Fig. *	Compressor	Connections (ID)		Receiver 90% Full (lbs.)	Fan(s) Data		Dimensions			Net Weight (lbs.)	Sound dBA**
			Liquid	Suction		CFM	No.	D (in.)	W (in.)	H (in.)		
TD040XR404A	A	2DL3F20KE	1/2"	1-1/8"	20	4350	1	38.1	46.4	46.4	740	78
TD060XR404A	A	3DA3F28KE	1/2"	1-1/8"	28	4280	1	38.1	46.4	46.4	780	81
TD075XR404A	B	3DB3F33KE	1/2"	1-1/8"	28	4310	1	38.1	50.3	50.3	800	81
TD100XR404A	C	3DS3F46KE	5/8"	1-1/8"	38	7730	2	38.1	58.2	58.2	1030	82

\*\* : Sound pressure are measured 10 feet from the product.

# CONDENSING UNITS

# R448A/449A

## Unit Spec - Medium Temp. Models - Scroll Compressors

Model Number	Compressor	Power Supply			Compressor		Fan Motor	MCA *	MOPD *
		Volts	Ph	Hz	RLA	LRA	FLA		
TS020MR404A3-T	ZB15KQE-TF5	208-230	3	60	8.9	55	0.94	15.0	20
TS025MR404A3-T	ZB19KQE-TF5	208-230	3	60	10	63	0.94	15.0	20
TS030MR404A3-T	ZB21KQE-TF5	208-230	3	60	12.1	77	2.40	17.5	25
TS040MR404A3-T	ZB29KQE-TF5	208-230	3	60	17.1	91	2.40	23.8	40
TS050MR404A3-T	ZB38KQE-TF5	208-230	3	60	22.1	128	2.40	30.0	50
TS060MR404A3-T	ZB45KQE-TF5	208-230	3	60	23.1	156	2.40	31.3	50
TS075MR404A3-T	ZB66KQE-TF5	208-230	3	60	26.9	225	4.80	38.4	60
TS100MR404A3-T	ZB95KQE-TW5	208-230	3	60	47.4	350	4.80	64.1	100

## Electrical Data - Extra Low Temp. Models - Scroll Compressors

Model Number	Compressor	Power Supply			Compressor		Fan Motor	MCA *	MOPD *
		Volts	Ph	Hz	RLA	LRA	FLA		
TS020XR404A2	ZF06K4E-PFV	208-230	1	60	13.6	61	0.94	17.9	30
TS025XR404A2	ZF08K4E-PFV	208-230	1	60	16.4	73	0.94	21.4	30
TS030XR404A2	ZF09K4E-PFV	208-230	1	60	14.3	88	0.94	18.8	30
TS035XR404A2	ZF11K4E-PFV	208-230	1	60	20.7	109	0.94	26.8	45
TS045XR404A2	ZF13K4E-PFV	208-230	1	60	26.8	129	2.40	35.9	60
TS055XR404A2	ZF15K4E-PFV	208-230	1	60	27.5	169	2.40	36.8	60

Model Number	Compressor	Power Supply			Compressor		Fan Motor	MCA *	MOPD *
		Volts	Ph	Hz	RLA	LRA	FLA		
TS020XR404A3	ZF06K4E-TF5	208-230	3	60	8.3	55	0.94	11.3	15
TS025XR404A3	ZF08K4E-TF5	208-230	3	60	9.6	63	0.94	12.9	20
TS030XR404A3	ZF09K4E-TF5	208-230	3	60	9.6	77	0.94	12.9	20
TS035XR404A3	ZF11K4E-TF5	208-230	3	60	13.6	88	0.94	17.9	30
TS045XR404A3	ZF13K4E-TF5	208-230	3	60	15.0	99	2.40	21.2	30
TS055XR404A3	ZF15K4E-TF5	208-230	3	60	18.9	123	2.40	26.0	45
TS060XR404A3	ZF18K4E-TF5	208-230	3	60	23.9	156	2.40	32.2	50
TS075XR404A3	ZF25K4E-TF5	208-230	3	60	26.1	189	2.40	35.0	60
TS100XR404A3	ZF34K5E-TFC	208-230	3	60	35.0	278	2.40	46.2	60

## Electrical Data - Semi-hermetic Compressors

Model Number	Compressor	Power Supply			Compressor		Fan Motor	MCA *	MOPD *
		Volts	Ph	Hz	RLA	LRA	FLA		
TD040XR404A	2DL3F20KE-TFC	208-230	3	60	23.6	161	2.40	31.9	50
TD060XR404A	3DA3F28KE-TFC	208-230	3	60	24.0	150	2.40	32.4	50
TD075XR404A	3DB3F33KE-TFC	208-230	3	60	27.6	161	2.40	36.9	60
TD100XR404A	3DS3F46KE-TFC	208-230	3	60	37.2	215	4.80	51.3	80

\* : MCA Minimum Circuit Ampacity does not include evaporators electrical requirements (evaporator fan motor amps, defrost heater amps).

# CONDENSING UNITS

# R448A/449A

## Performance Data - Medium Temp. Models - Scroll Compressors

R-448A R-449A Model	Compressor	Capacity BTU/HR @ 90°F. Ambient Suction Temperature °F							
		40°F	30°F	25°F	20°F	15°F	10°F	0°F	-10°F
TS015MR404A-T	ZS11KAE	16825	13660	12475	11230	10052	9098	7376	5903
TS020MR404A-T	ZB15KQE	23000	18690	16975	15190	13490	12125	9482	7565
TS025MR404A-T	ZB19KQE	28910	23700	21530	19145	17100	15275	12260	10031
TS030MR404A-T	ZB21KQE	34760	28400	25840	23200	20725	18480	14715	12075
TS040MR404A-T	ZB29KQE	44700	36680	33150	29800	26920	24240	19390	16040
TS050MR404A-T	ZB38KQE	55550	46610	42750	38770	34920	31500	25280	19160
TS060MR404A-T	ZB45KQE	67050	56250	51160	46360	42100	37710	30040	22740
TS075MR404A-T	ZB66KCE	102850	85767	77950	70400	63400	57330	45317	35013
TS100MR404A-T	ZB95KEC	140400	114900	104667	94000	84500	76650	59967	42340

R-448A R-449A Model	Compressor	Capacity BTU/HR @ 95°F. Ambient Suction Temperature °F							
		40°F	30°F	25°F	20°F	15°F	10°F	0°F	-10°F
TS015MR404A-T	ZS11KAE	16250	13185	12038	10860	9736	8852	7190	5784
TS020MR404A-T	ZB15KQE	22000	17790	16150	14450	12840	11440	9097	7390
TS025MR404A-T	ZB19KQE	27760	22650	20605	18310	16355	14650	11860	9917
TS030MR404A-T	ZB21KQE	33640	27150	24725	22200	19850	17705	14240	11950
TS040MR404A-T	ZB29KQE	43300	35400	31990	28520	25770	23100	18790	15890
TS050MR404A-T	ZB38KQE	53300	44740	41050	37220	33760	30460	23940	17900
TS060MR404A-T	ZB45KQE	64300	54000	49110	44510	40400	36470	28730	21540
TS075MR404A-T	ZB66KCE	100250	83100	76083	68400	61567	55510	43483	32747
TS100MR404A-T	ZB95KEC	133550	109400	100675	90550	81300	72650	56800	38540

R-448A R-449A Model	Compressor	Capacity BTU/HR @ 100°F. Ambient Suction Temperature °F							
		40°F	30°F	25°F	20°F	15°F	10°F	0°F	-10°F
TS015MR404A-T	ZS11KAE	15525	12650	11600	10460	9464	8562	7022	5672
TS020MR404A-T	ZB15KQE	21100	16870	15325	13700	12320	10890	8756	7288
TS025MR404A-T	ZB19KQE	26800	21600	19655	17630	15775	14150	11505	9870
TS030MR404A-T	ZB21KQE	32200	26400	23825	21200	18950	16970	13810	11855
TS040MR404A-T	ZB29KQE	41430	33800	30540	27220	24620	22340	18265	15820
TS050MR404A-T	ZB38KQE	51500	43220	39325	35670	32320	29160	23020	17100
TS060MR404A-T	ZB45KQE	61550	51750	47470	42660	38700	34920	27380	20300
TS075MR404A-T	ZB66KCE	96125	80200	73750	66400	59733	53643	41650	30480
TS100MR404A-T	ZB95KEC	127750	103800	94525	84850	75750	68350	53633	34740

R-448A R-449A Model	Compressor	Capacity BTU/HR @ 110°F. Ambient Suction Temperature °F							
		40°F	30°F	25°F	20°F	15°F	10°F	0°F	-10°F
TS015MR404A-T	ZS11KAE	14230	11650	10465	9484	8696	7820	6506	5438
TS020MR404A-T	ZB15KQE	19045	15350	13650	12240	11050	9832	8156	7096
TS025MR404A-T	ZB19KQE	24540	19665	17755	15960	14210	12850	10890	9925
TS030MR404A-T	ZB21KQE	29480	23900	21558	19170	17225	15580	13100	11915
TS040MR404A-T	ZB29KQE	37500	30500	27890	24880	22440	20400	17360	15940
TS050MR404A-T	ZB38KQE	47270	39800	36565	32880	29520	26560	20780	15100
TS060MR404A-T	ZB45KQE	56600	47250	43385	38980	35300	31820	24680	17800
TS075MR404A-T	ZB66KCE	87800	73300	67750	61600	55150	48940	-	-
TS100MR404A-T	ZB95KEC	-	94200	85275	76250	67700	54675	-	-

# CONDENSING UNITS

# R448A/449A

## Performance Data - Extra Low Temp. Models - Scroll Compressors

R-448A R-449A Model	Compressor	Capacity BTU/HR @ 90°F. Ambient Suction Temperature °F							
		0°F	-10°F	-15°F	-20°F	-25°F	-30°F	-35°F	-40°F
TS020XR404A	ZF06K4E	10650	8546	7651	6777	5970	5184	4491	3849
TS025XR404A	ZF08K4E	13430	10750	9541	8442	7343	6519	5687	4928
TS030XR404A	ZF09K4E	14690	11880	10600	9422	8348	7358	6466	5643
TS035XR404A	ZF11K4E	17880	14475	12975	11520	10194	9000	7900	6909
TS045XR404A	ZF13K4E	21960	17600	15613	13800	12060	10593	9247	8054
TS055XR404A	ZF15K4E	26980	21600	19233	17027	15080	13293	11567	10193
TS060XR404A	ZF18K4E	31700	25530	22940	20400	18007	15787	13920	12140
TS075XR404A	ZF25K4E	40000	32500	28887	25433	22560	19980	17507	15327
TS100XR404A*	ZF34K5E	50260	40850	36580	32590	28700	25053	21753	18727

\* : -T installed defrost timer

R-448A R-449A Model	Compressor	Capacity BTU/HR @ 95°F. Ambient Suction Temperature °F							
		0°F	-10°F	-15°F	-20°F	-25°F	-30°F	-35°F	-40°F
TS020XR404A	ZF06K4E	10350	8309	7440	6590	5803	5031	4347	3712
TS025XR404A	ZF08K4E	13005	10425	9270	8206	7228	6334	5520	4771
TS030XR404A	ZF09K4E	14240	11530	10234	9105	8076	7123	6260	5460
TS035XR404A	ZF11K4E	17290	14050	12525	11195	9914	8755	7692	6732
TS045XR404A	ZF13K4E	21280	16900	15020	13270	11640	10238	8936	7830
TS055XR404A	ZF15K4E	25930	20800	18540	16470	14600	12920	11250	9940
TS060XR404A	ZF18K4E	30500	24580	22140	19750	17400	15380	13620	11940
TS075XR404A	ZF25K4E	37720	30740	27500	24620	21870	19413	16987	15007
TS100XR404A*	ZF34K5E	48380	39500	35380	31330	27620	24300	21110	18100

\* : -T installed defrost timer

R-448A R-449A Model	Compressor	Capacity BTU/HR @ 100°F. Ambient Suction Temperature °F							
		0°F	-10°F	-15°F	-20°F	-25°F	-30°F	-35°F	-40°F
TS020XR404A	ZF06K4E	10110	8121	7240	6380	5620	4900	4202	3590
TS025XR404A	ZF08K4E	12490	10035	8995	7966	7023	6154	5360	4624
TS030XR404A	ZF09K4E	13763	11177	9927	8840	7846	6928	6085	5310
TS035XR404A	ZF11K4E	16690	13567	12117	10782	9627	8510	7482	6552
TS045XR404A	ZF13K4E	20413	16200	14420	12720	11240	9928	8716	7710
TS055XR404A	ZF15K4E	24860	20000	17840	15920	14000	12440	11000	9730
TS060XR404A	ZF18K4E	29200	23827	21340	19100	17000	14980	13320	11760
TS075XR404A	ZF25K4E	36253	29200	26160	23200	20593	18400	16480	14750
TS100XR404A*	ZF34K5E	46860	38000	34120	30247	26900	23550	20460	17600

\* : -T installed defrost timer

R-448A R-449A Model	Compressor	Capacity BTU/HR @ 110°F. Ambient Suction Temperature °F							
		0°F	-10°F	-15°F	-20°F	-25°F	-30°F	-35°F	-40°F
TS020XR404A	ZF06K4E	9522	7665	6856	6092	5373	4691	4030	3408
TS025XR404A	ZF08K4E	11623	9381	8373	7438	6569	5763	5020	4323
TS030XR404A	ZF09K4E	12797	10370	9301	8300	7380	6530	5737	5010
TS035XR404A	ZF11K4E	15310	12503	11200	10055	8938	7916	7032	6171
TS045XR404A	ZF13K4E	18547	14733	13160	11600	10304	9237	8316	7542
TS055XR404A	ZF15K4E	22660	18333	16380	14560	13000	11640	10389	9312
TS060XR404A	ZF18K4E	26600	21773	19580	17633	15900	14240	12780	11487
TS075XR404A	ZF25K4E	33300	27000	24360	21820	19527	17633	16000	14707
TS100XR404A*	ZF34K5E	42970	35000	31520	27980	24773	21960	19240	16647

\* : -T installed defrost timer

# CONDENSING UNITS

# R448A/449A

## Performance Data - Low Temp. Models - Semi-hermetic Compressors

R-448A R-449A Model	Compressor	Capacity BTU/HR @ 90°F. Ambient Suction Temperature °F						
		0°F	-10°F	-20°F	-25°F	-30°F	-35°F	-40°F
TD040XR404A	2DL3F20KE	32100	25180	18958	16218	13650	11428	9432
TD060XR404A	3DA3F28KE	45444	35372	26796	23180	19786	16900	14386
TD075XR404A	3DB3F33KE	53636	42164	32944	28784	24960	21200	17456
TD100XR404A	3DS3F46KE	76688	59344	45320	39100	33436	28020	23028

R-448A R-449A Model	Compressor	Capacity BTU/HR @ 95°F. Ambient Suction Temperature °F						
		0°F	-10°F	-20°F	-25°F	-30°F	-35°F	-40°F
TD040XR404A	2DL3F20KE	30788	23900	18958	15090	12770	10713	8918
TD060XR404A	3DA3F28KE	43164	33516	26796	21740	18682	15748	13440
TD075XR404A	3DB3F33KE	51196	40004	32944	26528	22800	19264	15824
TD100XR404A	3DS3F46KE	73128	56976	45320	36416	31148	26316	21374

R-448A R-449A Model	Compressor	Capacity BTU/HR @ 100°F. Ambient Suction Temperature °F						
		0°F	-10°F	-20°F	-25°F	-30°F	-35°F	-40°F
TD040XR404A	2DL3F20KE	29148	22812	16834	14338	11970	10017	8346
TD060XR404A	3DA3F28KE	41340	31980	28972	20588	17302	14724	12220
TD075XR404A	3DB3F33KE	49244	38276	29024	25024	21360	17856	14480
TD100XR404A	3DS3F46KE	69448	53952	40120	34464	28788	23580	19114

R-448A R-449A Model	Compressor	Capacity BTU/HR @ 110°F. Ambient Suction Temperature °F						
		0°F	-10°F	-20°F	-25°F	-30°F	-35°F	-40°F
TD040XR404A	2DL3F20KE	26380	20500	15106	12678	10690	8812	7360
TD060XR404A	3DA3F28KE	37132	28488	21020	17836	14734	12320	9954
TD075XR404A	3DB3F33KE	45124	34472	25888	21640	18120	14712	11092
TD100XR404A	3DS3F46KE	62768	48336	35248	29880	24420	19836	14988

# PACKAGE REFRIGERATION UNITS SMART<sup>7</sup>

## PACKAGE UNIT STANDARD FEATURES

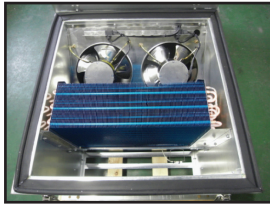

- **SM 1: Blue Anti-corrosion-fin and Coated Copper Tube**  
Protects aluminum and copper pipes from toxic gases generated from foods, retards refrigerant leakage, and prolongs the cooling capacity.

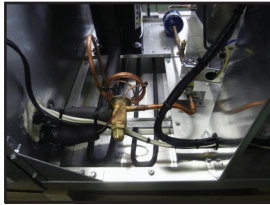

- **SM 2: Expansion Valve**  
Allows safe storage of foods with a feature that self-adjusts the circulation of refrigerant as the internal temperature changes, thus recovering the required temperature quickly.



- **SM 3: Compressor Protected Solenoid Valve**  
Decreases the inflow of refrigerant into the compressor when it is restarted after a stop. This extends compressor life and reduces compressor failure.

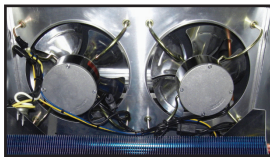

- **SM 4: 18% Bigger Condenser than the Standard**  
The condenser's efficiency affects most of the refrigerator's performance. Particularly, when used in a small compartment under high ambient temperatures or a dusty area, the package unit's condenser needs to be bigger than standard ones in order to achieve the best performance. In consideration of the environments that our products may be subject to, condensers utilized in our products are 18% larger than competitors'.

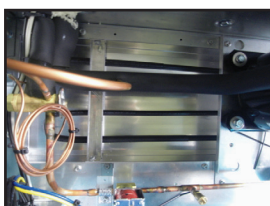

- **SM 5: Energy Efficient EC Motor**  
Through the use of highly efficient EC motors, our products reduce energy consumption and lower electricity costs, thus protecting the environment. Our products are designed with easy-to-replace motor and fan blades.



- **SM 6: Leak Free Patented Hot Gas Condensate System**  
The hot gas condensate system is an ideal system because of its fast evaporation of condensed water and its enhancing refrigeration efficiency. In spite of these advantages, many companies have stopped the application of such a system because of the high risk of discarding the refrigerators due to the rapid corrosion of hot gas lines causing refrigerant leakage and water inflow into the cooling pipes. Such problems are completely resolved in our products, thanks to a patented technology that prevents pipes from corrosion.

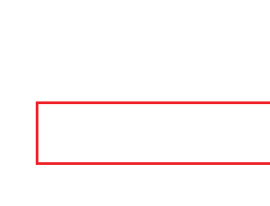

- **SM 7: Highly Efficient Air Circulation Enclosure**  
This system is designed to release hot air to the outside faster than competitors' and to enhance cooling efficiency. At the same time, it retards elevation of compressor temperature and keeps refrigerant pressure from increasing, thus saving energy as a result.



**All Replacement Parts are Universal!**

## DIMENSIONAL DATA

(unit : inch)

Figure A. Opening Size : 14 1/2" x 21"

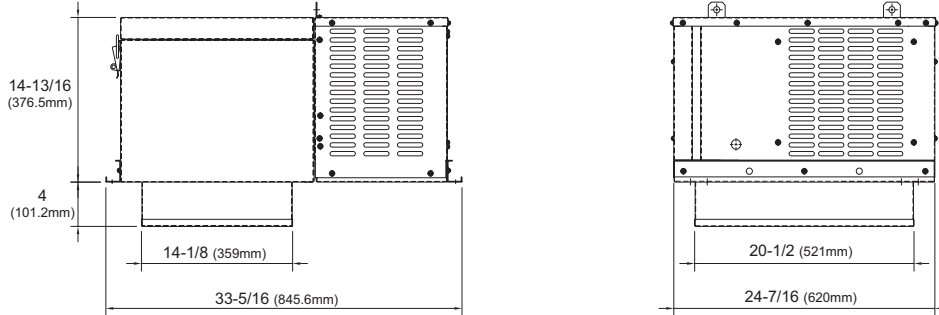

Figure B. Opening Size : 25" x 25"

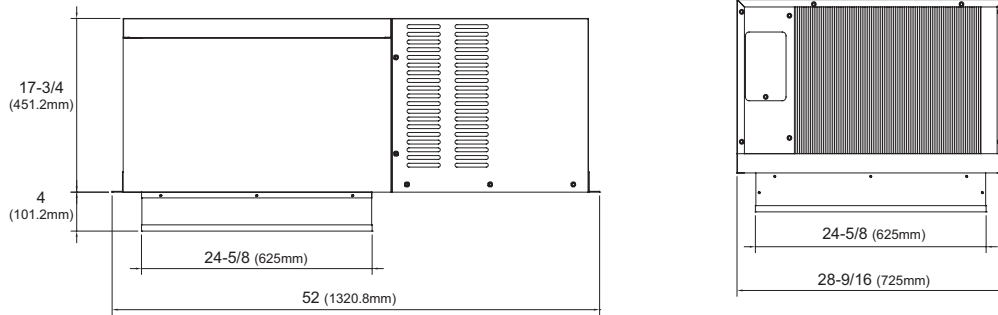
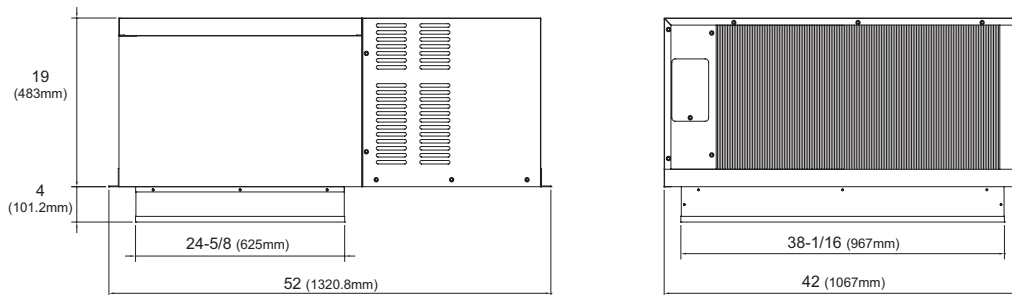

Figure C. Opening Size : 25" x 38 1/4"



# PACKAGE REFRIGERATION UNITS **SMART<sup>7</sup>**

## MODEL NOMENCLATURE

S	T	I	050	M	R404A	2
Model		Location	Capacity	Temp.	Refrigerant	Voltage
Turbo air Top Mount Package Unit		I= Indoor X= Outdoor	*= BTUH x 100	M= Medium Temp.  L= Low Temp.	R404A	1= 115V 1PH 60Hz  2= 208-230V 1PH 60Hz  3= 208-230V 3PH 60Hz

## TOP MOUNT PACKAGE UNIT

### Performance Data - Medium Temperature Models, Air Defrost

Model	Compressor	Capacity BTU / HR (Ambient Temp)														
		80°F			90°F			95°F			100°F			110°F		
		Room Temperature °F														
		34°F	35°F	38°F	34°F	35°F	38°F	34°F	35°F	38°F	34°F	35°F	38°F	34°F	35°F	38°F
ST * 030MR404A	SC15MLX.2	3168	3223	3415	3151	3207	3403	3126	3183	3380	3101	3158	3357	3038	3102	3303
ST * 050MR404A	SC15MLX.2	5560	5710	5929	5135	5254	5547	4922	5026	5356	4792	4893	5216	4401	4495	4795
STI * 068MR404A	NT6228GKV	9147	9322	9880	8255	8416	8924	7594	7743	8213	7310	7454	7908	6326	6452	6852
ST * 075MR404A	NTU6232GKV	9141	9354	10086	8764	8968	9668	7878	8059	8675	7498	7670	8250	6448	6598	7103
ST * 100MR404A	CS10K6E	13696	14028	15064	11577	11868	12784	11365	11652	12556	10528	10799	11651	9288	9537	10305
ST * 130MR404A	CS12K6E	16104	16508	17864	15640	16036	17368	14712	15092	16376	13784	14148	15384	13320	13676	14888

### Performance Data - Low Temperature Models, Electric Defrost

Model	Compressor	Capacity BTU / HR (Ambient Temp)														
		80°F			90°F			95°F			100°F			110°F		
		Room Temperature °F														
		0°F	-10°F	-20°F	0°F	-10°F	-20°F	0°F	-10°F	-20°F	0°F	-10°F	-20°F	0°F	-10°F	-20°F
ST * 022LR404A	AFT29C1E	3348	2852	1982	3028	2583	1769	2849	2423	1643	2664	2254	1516	2334	1920	1076
ST * 045LR404A	CF06K6E	7416	5621	4342	6336	4962	3680	5957	4603	3514	5510	4215	3234	4604	3652	2814
ST * 055LR404A	CF06K6E	8584	6707	4883	7789	6051	4179	7395	5406	4002	6478	5105	3696	5449	4215	3041
ST * 070LR404A	CF09K6E	11535	9388	6945	9868	8227	5948	9139	7520	5439	8241	6825	4940	7703	5603	4100



# PACKAGE REFRIGERATION UNITS **SMART<sup>7</sup>**

## UNIT SPECIFICATIONS - MEDIUM TEMPERATURE INDOOR MODELS

Model	Power Supply			MCA	MOPD	Unit Amps	Evaporator fan Qty/CFM	Plug Supplied	Matching NEMA Receptacle	Dim. Fig.	Refrigerant		Sound dBA **	Net Weight lbs. (kg)
	Voltage	PH	Hz								Ref.	Wt oz		
STI030MR404A1	115	1	60	7.1	15	5.8	1 / 350	YES	5-20R	A	R404A	18	67	130 (59)
STI050MR404A1	115	1	60	11.3	20	9.3	1 / 360	YES	5-20R	B	R404A	28	67	195 (89)
STI050MR404A2	208-230	1	60	4.7	15	3.9	1 / 360	YES	6-15R	B	R404A	28	67	195 (89)
STI068MR404A2	208-230	1	60	8.9	15	7.34	2 / 510	YES	6-15R	B	R404A	42	68	216 (98)
STI075MR404A2	208-230	1	60	9.2	15	7.54	2 / 510	YES	6-15R	B	R404A	42	68	226 (103)
STI100MR404A2	208-230	1	60	14.0	20	11.6	3 / 890	YES	6-20R	C	R404A	53	71	311 (141)
STI100MR404A3	208-230	3	60	10.1	15	8.5	3 / 890	NO	-	C	R404A	53	71	318 (145)
STI130MR404A2	208-230	1	60	14.0	20	11.6	3 / 840	NO	-	C	R404A	60	73	320 (145)
STI130MR404A3	208-230	3	60	9.9	15	8.3	3 / 840	NO	-	C	R404A	60	73	317 (144)

## UNIT SPECIFICATIONS - MEDIUM TEMPERATURE OUTDOOR MODELS

Model	Power Supply			MCA	MOPD	Unit Amps	Evaporator fan Qty/CFM	Plug Supplied	Matching NEMA Receptacle	Dim. Fig.	Refrigerant		Sound dBA **	Net Weight lbs. (kg)
	Voltage	PH	Hz								Ref.	Wt oz		
STX050MR404A2	208-230	1	60	4.7	15	3.9	1 / 360	NO	-	B	R404A	28	67	205 (93)
STX075MR404A2	208-230	1	60	6.0	15	5	2 / 510	NO	-	B	R404A	42	68	236 (107)
STX100MR404A2	208-230	1	60	14.0	20	11.6	3 / 890	NO	-	C	R404A	53	71	319 (145)
STX100MR404A3	208-230	3	60	10.1	15	8.5	3 / 890	NO	-	C	R404A	53	71	327 (148)
STX130MR404A2	208-230	1	60	14.0	20	11.6	3 / 840	NO	-	C	R404A	60	73	329 (149)
STX130MR404A3	208-230	3	60	9.9	15	8.3	3 / 840	NO	-	C	R404A	60	73	325 (148)

## UNIT SPECIFICATIONS - LOW TEMPERATURE INDOOR MODELS

Model	Power Supply			MCA	MOPD	Unit Amps	Evaporator fan Qty/CFM	Plug Supplied	Matching NEMA Receptacle	Dim. Fig.	Refrigerant		Sound dBA **	Net Weight (lbs.)
	Voltage	PH	Hz								Ref.	Wt oz		
STI022LR404A2	208-230	1	60	8.0	15	6.5	1 / 360	YES	6-15R	B	R404A	24	67	203 (92)
STI045LR404A2	208-230	1	60	16.4	25	13.3	2 / 510	YES	6-20R	B	R404A	28	73	238 (108)
STI055LR404A2	208-230	1	60	19.5	30	16	3 / 890	YES	6-20R	C	R404A	46	69	312 (142)
STI055LR404A3	208-230	3	60	13.3	20	11	3 / 890	NO	-	C	R404A	46	69	308 (140)
STI070LR404A2	208-230	1	60	19.8	30	16.2	3 / 840	NO	-	C	R404A	46	76	319 (145)
STI070LR404A3	208-230	3	60	13.9	20	11.5	3 / 840	NO	-	C	R404A	46	76	316 (144)

## UNIT SPECIFICATIONS - LOW TEMPERATURE OUTDOOR MODELS

Model	Power Supply			MCA	MOPD	Unit Amps	Evaporator fan Qty/CFM	Power Cord	Matching NEMA Receptacle	Dim. Fig.	Refrigerant		Sound dBA **	Net Weight (lbs.)
	Voltage	PH	Hz								Ref.	Wt oz		
STX022LR404A2	208-230	1	60	8.0	15	6.5	1 / 360	NO	-	B	R404A	28	67	213 (97)
STX045LR404A2	208-230	1	60	16.4	25	13.3	2 / 510	NO	-	B	R404A	42	73	248 (113)
STX055LR404A2	208-230	1	60	19.5	30	16	3 / 890	NO	-	C	R404A	53	69	320 (145)
STX055LR404A3	208-230	3	60	13.3	20	11	3 / 890	NO	-	C	R404A	53	69	317 (144)
STX070LR404A2	208-230	1	60	19.8	30	16.2	3 / 840	NO	-	C	R404A	60	76	328 (149)
STX070LR404A3	208-230	3	60	13.9	20	11.5	3 / 840	NO	-	C	R404A	60	76	324 (147)

\* MCA : Minimum Circuit Ampacity \* MOPD: Maximum ratings Of Protection Device \* CFM: Cubic Feet per Minute

# PRODUCT AND SERVICE

## IMPORTANT PRODUCT AND SERVICE DETAILS

We want to provide the information you need to take advantage of the great products and services in this catalog. If you don't find what you need here, please go online or call for more information.

### ■ Changes:

- Price, products and offers in the catalog may change without notice.
- Turbo Air cannot be responsible for pricing or other errors, and reserves the right to cancel orders arising from such errors.

### ■ Prices:

- Our catalog prices do not include taxes and other fees (applicable for U.S. only).

### ■ Shipping and Handling Charges:

- Turbo Air will **offer free shipping and handling** under the following conditions:
  - The amount of one order is more than US \$5,000.
  - Any combination of 5 or more products.

### ■ Warranties:

- 1 year parts and 1 year compressor warranty in condensing units and unit coolers. (No labor)  
(4 year extended warranty available for compressor: totally 5 years)
- 2 year parts and 2 year compressor and 1 year labor in packaged refrigeration units. (Smart 7)  
(3 year extended warranty available for compressor: totally 5 years)

*For more detail, please refer to the "Warranty Statement" at our website - [www.turboairinc.net](http://www.turboairinc.net)*

### ■ Exchange and Returns:

- Under the following conditions you can simply **return the ordered products without any charge**.
  - You received different models due to our errors.
  - Delivery was delayed more than 3 days from the promised date.
  - Arrived product shows signs of external damage.
- If any products does not meet your expectations, you may return the products within 7 days after receiving return confirmation from Turbo Air. The returned products must be insured and prepaid. Please enclose your copy of the invoice or packing slip with the return. Please indicate whether you wish to exchange for another product(s), receive credit, or request a full refund of the purchase price. All products must be in new condition with original packaging and all included accessories. Please note that there will be a 20% restocking and repacking fee from the purchase price.

### ■ Freight Damage:

- Inspection of the shipment is the consignee's obligation. Please make sure you are receiving the right merchandise in good condition at the delivery site. If in doubt, write a note of "Damaged" on the delivery receipt before signing it. Afterwards, notify the carrier and file a claim even if the damage was found later. Please retain all cartons and product for inspection. Turbo Air is willing to assist and support you in filing your claim, but the action of filing the claim must be taken by you.

# WARRANTY STATEMENT

## **R404A / PACKAGE REFRIGERATION SYSTEMS (Smart 7)**

Turbo Air Corp. warrants that R404A package refrigeration products will conform to the manufacturer's specifications and will be free of defects in material and workmanship. Should any defects occur, Turbo Air Corp. will correct the defects subject to the following conditions.

**PARTS:** For a period of two year from date of sale or installation, Turbo Air Corp. will supply new, or at its option rebuilt replacement parts.

**COMPRESSOR:** For a period of two year or for a period of five years (if purchased separately) from date of sale or installation (Not to be exceeded 20 months from factory ship date), Turbo Air Corp. will supply a new compressor.

**LABOR:** For a period of one year from date of sale or installation, Turbo Air Corp. will arrange service technician to diagnose and solve problem on the unit.

**PROOF OF PURCHASE:** Copy of the proof of purchase is required to make this warranty valid. Or a valid manufacture's serial number of the unit is required.

## **R404A / REMOTE REFRIGERATION SYSTEMS**

Turbo Air Corp. warrants that R404A remote refrigeration products will conform to the manufacturer's specifications and will be free of defects in material and workmanship. Should any defects occur, Turbo Air Corp. will correct the defects subject to the following conditions.

**PARTS:** For a period of one year from date of sale or installation (Not to exceed 20 months from factory ship date), Turbo Air Corp. will supply new, or at its option rebuilt replacement parts.

**COMPRESSOR:** For a period of **one year** or for a period of **five years (if purchased separately)** from date of sale or installation (Not to be exceeded 20 months from factory ship date), Turbo Air Corp. will supply a new compressor.

**PROOF OF PURCHASE:** Copy of the proof of purchase is required to make this warranty valid. Or a valid manufacture's serial number of the unit is required.

### **THIS WARRANTY DOES NOT COVER LABOR OR:**

- Shipping damage.
- System installation.
- Unpacking and/or removal of protective shipping material.
- Usage outside manufacturer's limitations as specified in the owner's manual.
- Service required as a result of improper installation, incorrect or insufficient AC supply voltage.
- Installation, set up, or adjustments of consumer controls.
- Any owner than the original owner.
- Damage from modification into other products.
- Any failure, loss, damage or person injury due to accident, neglect, or abuse by the consumer or to improper operation, maintenance or storage or to alteration or to failure to follow normal procedures as outlined in the instruction manual.
- Any unit purchased from an unauthorized dealer, any online retailer or not directly from Turbo air.
- Transportation charges incurred in connection with warranty service.
- Indirect, consequential, or special damages, except as required by Federal or State laws.
- Repair or replacement of warranted part by other than qualified installer.

**THE WARRANTY AND REMEDY STATED ABOVE ARE EXCLUSIVE AND IN LIEU OF ALL OTHER EXPRESS OR IMPLIED WARRANTIES INCLUDING, BUT NOT LIMITED TO, THE IMPLIED WARRANTIES OF MERCHANTABILITY OR FITNESS FOR A PARTICULAR PURPOSE. SOME LAWS DO NOT ALLOW EXCLUSION OF IMPLIED WARRANTY, THEREFORE THIS WARRANTY SHALL BE DEEMED MODIFIED TO BE CONSISTENT WITH SUCH LAWS.**

Some states do not allow limitation on how long an implied warranty lasts; therefore these limitations or exclusions may not apply to you. This limited warranty gives you specific legal rights. You may also have other rights that may vary from state to state. This warranty applies to the United States.

# **Texaking**

1800 S. Great SW Pkwy., Grand Prairie, TX 75051

PRESORTED STD  
U.S POSTAGE  
**PAID**  
LOS ANGELES, CA  
PERMIT NO. 199

# **Texaking**

1800 S. Great SW Pkwy., Grand Prairie, TX 75051

Toll Free : 1-800-828-2706 / Fax : 214-723-7215

[www.texaking.com](http://www.texaking.com)